



HK3 V6

Water cooling container & Dry-Wet Tower Product Manual

Apr. 2024

BITMAIN

BITAMIN TECHNOLOGIES INC.

www.bitmain.com

Declaration

The purpose of the Product Use and Maintenance Manual (hereinafter referred to as the product manual) is only to provide guidance information to help you correctly use the ANTSPACE HK3 container Water cooling system (hereinafter referred to as this product). Before installing and using this product for the first time, you are obligated to carefully read all the materials delivered, especially the precautions mentioned in the product manual, which will help you better and safely use this product. Please keep the product manual properly for future reference.

Before using this product, please check if the product components are complete. If there are any missing parts, please contact BITMAIN in a timely manner and carefully inspect the product before installation and use.

When the following situations cause property damage to you or third-party personnel, BITMAIN will not be responsible, and the product damage caused is not covered by the warranty. If the user requests repair services, after being determined by the BITMAIN service organization, paid repair services can be provided.

1. The entire equipment and components of this product have exceeded the free warranty period, or have been damaged due to abnormal use or natural environment.
2. Incorrect or failure to install, use, and store this product according to the instructions and requirements of the product manual.
3. Operate this product under operating environmental conditions that exceed the requirements specified in the product manual.
4. Exceeding the installation and use scope specified in international standards or local laws, regulations, and industry regulations.
5. Repairs or changes to this product by non BITMAIN authorized technical personnel;
6. Use the software provided with the product outside of this product, or use other software other than non random software or specialized software on this product.
7. Other scenarios that do not require liability within the legal scope of the country (region) where the operation is carried out.

Special attention: If the user purchases this product from a non BITMAIN official sales channel, BITMAIN does not guarantee that the product manual can be fully transmitted. Training and services related to installation, use, maintenance, etc. should be provided by the seller. When using this product, it is assumed that the user is aware of the relevant installation, use, and maintenance content of the product, which also applies to the content of this declaration.

The product manual is not intended to indicate that BITMAIN has made any promises or warranties regarding its products and services, whether express or implied, including but not limited to the warranties of suitability, safety, and suitability for a specific purpose recommended in the product manual.

The photos, graphics, charts, and illustrations provided in the product manual are for explanatory and explanatory purposes only, and may differ from the actual product. The actual specifications and configurations of the product may change from time to time as needed, so they may differ from the content of the product manual. Please refer to the actual product purchased.

Due to the continuous iteration of products and the application of new designs, materials, and technologies, BITMAIN will make improvements or modifications to the software and hardware described in the product manual and the content of the product manual at any time based on factors including but not limited to product characteristics, product performance, and usage environment, without prior notice. If you find any inconsistencies between the actual situation of this product and the product manual during use, or if you want the latest information or have any questions or ideas, please feel free to call us or log in to the service website for inquiries.

Change History

Version	Change Items	Before Changing	After Changing	Change Time	Change By
V1.0.9	Initial version	/	/	2023.7.4	
V2.0.5	Split manual versions by cooling method	/	/	2024.4.12	

Copyright © BITMAIN TECHNOLOGIES INC. All rights reserved.

- Without the authorization of BITMAIN, the relevant contents of this manual shall not be spread, copied or forwarded to a third party, nor uploaded to a third-party platform such as the public network.

Trademark

- As well as other BIMAIN and ANTSPACE trademarks used in this manual, they belong to BITMAIN TECHNOLOGIES INC.
- All other trademarks or registered trademarks mentioned in this manual belong to their respective owners.

Software Authorization

- It is prohibited to use part or all of the data in the firmware or software developed by our company for commercial purposes in any way.
- Prohibit decompilation, decryption, or other operations that disrupt the original program design of the software developed by our company.

BITMAIN TECHNOLOGIES INC.

Official website: www.bitmain.com

Contents

1 About This Document	1
1.1 Application Scope	1
1.2 Intended Audience.....	1
1.3 Use of Manual	1
1.4 Symbol Conventions.....	1
2 Safety Description.....	3
2.1 General Safety Instructions	3
2.2 All Safety Instructions	3
2.3 Electrical Safety	4
2.4 Mechanical Safety	5
2.5 Operation Safety.....	6
2.6 Others.....	6
3 ANTSPACE HK3 V6 Container Water Cooling System Composition and Working Principle.....	8
3.1 System Overview	8
3.2 System Composition.....	8
3.3 Working Principle	9
4 ANTSPACE HK3 V6 Container Water Cooling System Performance Index Requirements	11
5 ANTSPACE HK3 V6 Container Water Cooling System Structural Views.....	13
5.1 External View of Container Water Cooling System	13
5.2 Internal View of Container Water Cooling System	14
6 ANTSPACE HK3V6 Container Water Cooling System Composition.....	18
6.1 ANTSPACE HK3V6 Container Water Cooling System Composition	18
6.2 Installation and Connection of Container Water Cooling and Cooling Tower.....	19
6.3 Installing Exhaust Fans for Container Water Cooling.....	19
6.4 Container Water Cooling System Pipeline Connection.....	20
7 ANTSPACE HK3 V6 Container Water Cooling System Use and Operation.....	23
7.1 Safety Rules	23
7.2 System Pressurization.....	25
7.3 System Water Replenishment	31
7.4 Electrical Wiring	36
7.5 System Power-on and Power-off.....	42
7.6 Touch Screen Operation	47
7.7 ANTSPACE HK3 V6 Container Water Cooling System On-site Installation Summary ...	57
8 ANTSPACE HK3 V6 Container Water Cooling System Conventional Faults and Troubleshooting	60
9 ANTSPACE HK3V6 Container Water Cooling System Maintenance.....	67
9.1 Overview.....	67

9.2 Preventive Maintenance.....	67
9.3 Regular Inspections	68
10 ANTSPACE HK3 V6 Container Water Cooling System Safety Instructions.....	79
10.1 Maintenance	79
10.2 Operation.....	79
10.3 Attention	80

1 About This Document

This manual mainly introduces the working principle, fault handling, and maintenance methods of the ANTSPACE HK3V6 Water cooling system.

1.1 Application Scope

This manual is applicable to the ANTSPACE HK3 V6 model.

1.2 Intended Audience

This manual is applicable to professional technical personnel who need to install, operate, and maintain the product. Professional technical personnel must meet the following requirements:

- Possess certain professional knowledge in electronics, electrical wiring, and machinery, and be familiar with electrical and mechanical schematic diagrams.
- Familiar with the composition and working principles of Water cooling systems and related products.
- It should have received professional training related to the installation and trial operation of electrical products.
- It should have the ability to respond urgently to hazards or unexpected situations that occur during installation or trial operation.
- Familiar with the relevant standards and specifications of the country/region where the project is located.

1.3 Use of Manual

Please read the manual carefully before using the product.

The content of the manual will continue to be updated and corrected, but it is inevitable that there may be slight discrepancies or errors with the actual product. Users should refer to the actual product they purchased and can download or obtain the latest version of the manual materials through www.bitmain.com or sales channels.

1.4 Symbol Conventions

In order to ensure the personal and property safety of users when using the product, and to use the product more efficiently and optimally, the manual provides relevant information and highlights it with the following symbols.

The following are the symbols that may be used in this manual. Please read carefully to better use this manual.



Danger

Indicates a high potential danger that, if not avoided, could result in serious accidents such as personal injury, equipment damage, etc.



Warning

Indicates a moderate potential hazard, which, if not avoided, could result in serious accidents such as equipment damage.



Caution

Indicates a potential danger that, if not avoided, may result in the equipment not functioning properly.

2 Safety Description

2.1 General Safety Instructions

DISCLAIMER: The equipment company is not responsible for any of the following situations.

- Operation beyond the conditions specified in this document.
- Usage under installation and operating environments which are not specified in related international specifications.
- Failure to follow the operation instructions and safety precautions on the product and in the document.
- Damage caused by abnormal natural environments.

2.2 All Safety Instructions

To ensure safety of humans and the equipment, pay attention to the safety symbols on the equipment and all the safety instructions in this document.

The "NOTICE", "CAUTION", "WARNING" and "DANGER" marks in this document do not represent all the safety instructions. They are only supplements to the safety instructions.

- **Local Safety Regulations**

When operating the equipment, you must follow the local laws and regulations. The safety instructions in this document are only supplements to the local laws and regulations.

- **Personal Requirements**

Only trained and qualified personnel are allowed to install, operate, and maintain Bitmain equipment, and they must understand basic safety precautions to avoid hazards.

Only trained and qualified personnel are allowed to install, operate, and maintain Bitmain equipment.

Only personnel certified or authorized by equipment provider are allowed to replace or change the equipment or components (including software).

Any fault or error that might cause safety problems must be reported immediately to a supervisor.

- **Grounding Requirements**

Equipment to be grounded must meet the following requirements:

When installing the device, always make the ground connection first and disconnect it at the end.

Do not damage the ground conductor.

Do not operate the equipment in the absence of a properly installed ground conductor.

Ensure that the equipment is connected permanently to the protective ground.

- **Personal Safety**

Keep irrelevant people away from the equipment. Only operators are allowed to access the equipment.

Before operating a device, wear insulated shoes and insulated gloves, and pay attention to eye protection. Remove conductive objects such as jewelry and watches to avoid electric shocks or burns.

Ensure that tool handles are insulated.

- **Equipment Safety**

Put away the keys to the device when installation, operation and maintenance.

Before operations, ensure that the equipment is firmly secured to the floor or other solid objects, such as a wall or an installation rack.

Do not block the ventilation while the device is operating.

Tighten the screws by using a tool after initial installation and subsequent access to the panel.

After the installation, remove packing materials from the equipment area.

2.3 Electrical Safety

- **High Voltage**

 **Danger**

The high-voltage power supply provides power for the operation of the equipment. Direct contact or indirect contact with the high-voltage power supply through wet objects (or conductors) is fatal. Irregular and incorrect high-voltage operation may cause accidents such as fire or electric shock. Signal wires should be tied separately from high-current wires or high-voltage wires.

- **High Electrical Leakage**

 **Danger**

1. Before turning on the power, all components of the equipment and the general grounding wire must be grounded, otherwise personal and equipment safety will be endangered.
2. If a "large leakage current" sign is pasted near the power terminal of the equipment, the protective grounding terminal of the equipment chassis must be grounded before connecting to the AC input power supply to prevent the equipment's leakage current from causing electric shock to the human body.
3. Exposed cables in the equipment should be insulated immediately.

- **Power Cable**

 **Danger**

It is prohibited to install or remove the power cord while the power is on. The moment the power cord core comes into contact with a conductor, arcs or sparks will occur.

Before installing or removing a power cable, turn off the power switch.

Before connecting a power cable, check that the label on the power cable is correct.

If the power cable is damaged, it must be replaced by the manufacturer, its service agent or similarly qualified persons in order to avoid a hazard.

The appliance should fit with means for disconnection from the supply mains having a contact separation in all poles that provide full disconnection under overvoltage category III conditions, and these means must be incorporated in the fixed wiring in accordance with the wiring rules.

2.4 Mechanical Safety

- **Drilling Holes**

 **Warning**

It is prohibited to drill holes in the cabinet by yourself. Drilling holes that do not meet the requirements will damage the internal components or pipelines of the equipment and damage the internal cables.

- **Sharp Objects**

The fins of the heat exchanger of dry tower are extremely sharp. Please wear protective gloves when operating close to the fins.

 **Warning**

When carrying the equipment by hand, you should wear protective gloves to prevent your hands from being cut by the sharp corners of the equipment.

- **Fan**

When replacing a component, place the component, screws, and tools in a safe place. Otherwise, if any of them fall into the operating fans, the fans may be damaged.

When replacing a component near fans, do not insert your fingers or boards into the operating fans until the fans are switched off and stops running.

- **Moving Heavy Objects**

Warning

1. Please wear protective gloves when carrying heavy objects to avoid scratching your hands.
2. When carrying heavy objects, be prepared to bear the weight to avoid being crushed or sprained by heavy objects.
3. When pulling the equipment out of the cabinet, be careful because the equipment installed on the cabinet may be unstable or heavy to avoid being crushed or hit.
4. It is prohibited for one person to carry heavy equipment alone. When transporting the device, do not tilt the device more than 15° (relative to vertical).
5. When moving or lifting the equipment, please protect the equipment to avoid scratches or bumps.
6. When transporting, it is strictly prohibited to use the components as a supporting point to prevent damage to the components.

2.5 Operation Safety

- **High Temperature and Pressure**

Misoperations may cause over high pressure, which may result in eruption of coolant.

Pay attention to high-pressure parts: exhaust valves and drain valves.

- **High Speed Running**

Pay attention to high-speed running part: fan.

2.6 Others

- **Binding Signal Cables**

Caution

Bundling signal wires should be bundled separately from high-current wires or high-voltage wires.

- **Laying Out Power Cables**

When the temperature is very low, violent strike or vibration may damage the power cable sheathing. To ensure safety, comply with the following requirements:

Power cables can be laid or installed only when the temperature is higher than 0°C.

Before laying out power cables which have been stored in a temperature lower than 0°C, move the power cables to an environment of the ambient temperature and store them at the ambient temperature for at least 24 hours.

Handle power cables with caution, especially at a low temperature. Do not drop the power cables directly from the vehicle.

- **Storage**

Do not store devices near a heat source or under direct sunshine.

Keep devices away from fire or high-temperature objects, especially devices injected with pressurized nitrogen or refrigerant; otherwise, explosion or refrigerant leakage may occur, causing personal injury.

- **Recovery and Disposal**

The sign indicates that the product cannot be disposed of with other wastes that have a shell in European Union (EU) areas. To prevent possible harm to the environment or human health from uncontrolled waste disposal, recycle it responsibly to promote the sustainable reuse of material resources.



Figure 2-1 Recycle marking

3 ANTSPACE HK3 V6 Container Water Cooling System Composition and Working Principle

3.1 System Overview

The container Water cooling system aims to continuously provide cooling Water that meets the pressure, temperature, and flow requirements for the heat dissipation unit of the internal high computing power server, ensuring a good working environment for the load.

There are three types of heat dissipation options for container Water cooling systems: evaporative cooling (dry wet combined dry tower), water-water heat exchange (plate exchange component), and forced air cooling (dry tower). The internal cooling medium can be selected according to the local environmental temperature, such as suitable antifreeze, deionized water, or pure water.

3.2 System Composition

Table 3-1 Main components of container Water cooling system

Sub system	Function	Main components
Pumping station	Transport and monitor the cooling Water status to maintain stable system operation	Centrifugal pumps, expansion tanks, sensors, valves, exhaust valves, filters, pipelines, and other related accessories
Control cabinet	Control the operation of various components in the pump station, read the numerical display of each sensor, and upload it	Circuit breakers, intermediate relay, PLC, switch power supply, touch screen, and other related accessories
Network and distribution system	Distribute network and power for high computing power servers	Circuit breakers, aviation plugs, cables, switches, and other related accessories
Mainfold system	Flow distribution and transportation	Main fold, elbows, hoses, chucks, valves, and other related accessories
Accessories	Supporting components and spare accessories required for the use of container Water cooling system	Screws, miniature circuit breakers, aviation plugs, clamps, rubber hoses and other related accessories
Dry wet tower (optional)	Transfer heat from the load to the atmosphere	Spray pumps, coolers, air inlet grilles, fans, and other related accessories
Dry tower (optional)	Transfer heat from the load to the atmosphere	Stainless steel heat exchanger components, valves, pressure gauges, and other related accessories
Plate heat exchanger component (optional)	Transfer heat from the load to the cold side water	Plate heat exchangers, sensors, valves, and other related accessories

3.3 Working Principle

Pump Station

The pump station provides two cooling Waters that meet the requirements for temperature, pressure, flow rate, and medium to the Water distributor components. After two stages of Water separation, the water separator delivers the cooling Water to the water-cooled plate, which takes away the heat inside the equipment.

The heated cooling Water enters the cooling tower for forced heat exchange with the external air, or enters a plate heat exchanger for heat exchange with the external cold source. The cooled cooling Water is then transported to the water-cooled plate again through the pump station and water separator components for circulation, thereby taking away the heat inside the heating load and ensuring that the heating load operates in a good environment.

Dry Wet Tower

The dry wet tower for both dry and wet use should be used for both dry and wet working conditions. The working principle of wet working conditions is to use water and air as cooling media, and use the evaporation of some cooling water to carry away the heat released by the cooling Water during the flow process inside the coil. Internally equipped with: spray device, serpentine condensing coil, (filler heat exchange layer) dehydrator, bottom with a water collection tank, external spray pump, and top with an axial flow fan. During operation, cooling water is pumped from the spray pump to the upper part of the condensing disc and the Water condensed by the cooling water outside the tube flows out from the lower part of the condensing disc. After absorbing the heat of the coolant, a portion of the water evaporates into water vapor, which is sucked away by an axial flow fan and discharged into the atmosphere. The non evaporative cooling water drips into the lower collection tank for circulation by the spray pump. The axial flow fan draws air from the top, strengthening air flow, causing the water collection tank to bear negative pressure, reducing the evaporation temperature of water, accelerating water film evaporation, and strengthening the heat release of the condensing coil. The function of a dehydrator is to block non evaporative water droplets in the air and allow them to flow back to the collection tank, in order to reduce the consumption of cooling water. In addition, a floating ball valve is also installed in the water collection tank. When the water continuously evaporates and consumes, the floating ball valve automatically opens to provide supplementary spray water. The working principle of dry working condition is to forcibly exchange heat between the cooling Water with high temperature from the water-cooled plate and low-temperature air, and the

cooling Water with reduced water temperature enters the system again through the pump unit for heat dissipation.

Dry Tower

Similar to the dry wet tower, the dry tower uses a power fan to force air convection to achieve heat exchange between the air and the internal circulating medium, thereby achieving overall heat dissipation.

Plate Heat Exchanger

During the operation of a plate heat exchanger, a thin rectangular fluid channel is formed between each heat exchange plate. The cold and hot heat exchange media enter these narrow and tortuous flow channels through the holes at the four corners of the plate. The ripples on the plate enhance the stiffness of the plate and also enhance the turbulence of the fluid. Two types of media form a parallel flow or a reverse flow between the plates, and heat exchange is carried out through the intermediate layer plates to achieve the purpose of use.

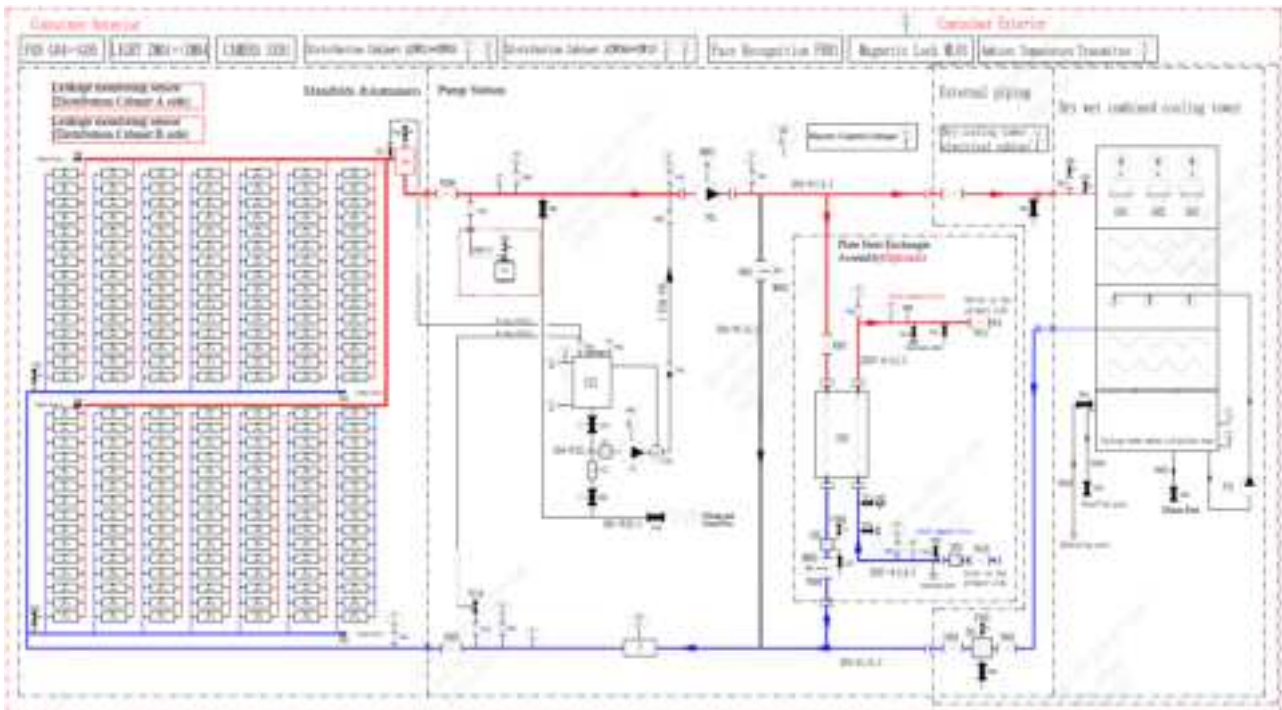

Figure 3-1 Dry Wet Tower Schematic diagram of container Water cooling system

4 ANTSPACE HK3 V6 Container Water Cooling System Performance Index Requirements

Table 4-1 System performance index requirements

SN	Items	Performance index	Remarks
Environment			
1	Working temperature	-35~40°C	Outdoor
	Working temperature	5~40°C	Indoor (controllable temperature range by adjusting the fan)
2	Working humidity	10~90%	
3	Storage temperature	-35~70°C	
4	Storage humidity	5~95%	
5	Altitude	≤2000m	
Container technology			
1	External dimensions (L×W×H) (mm)	6058×2438×2896	
2	High computing power server capacity	210 S21 Hyd. series and S19 Hyd. series high computing servers	
3	Box certification	China Classification Society Certification	
4	Safety certification	NFPA 79:2021 UL 508A:2018 R8.21 CSA C22.2 No. 14-18 ANSI/ISO 12100:2012	
5	Operating power(kW)	1047~1050	Excluding dry wet tower power consumption
6	Input voltage and power	AC 400V±5%, 60Hz/50Hz	
7	Transport weight (T)	8	Excluding high computing power servers and water cooling
8	Operating weight (T)	12	Including high computing power servers and water cooling
9	Main switch capacity of distribution cabinet (A)	1200	The container Water cooling system includes two distribution cabinets, each with a 1200A main switch

SN	Items	Performance index	Remarks
10	Rated current (A)	≤986	Rated current of each distribution cabinet inside the container
11	Standard power (kW)	1047	Excluding cooling tower power consumption
12	Maximum power (kW)	1050	Excluding cooling tower power consumption
13	Single unit rated current (A)	≤10	The container Water cooling system includes two distribution cabinets, each with a 1200A main switch
14	Provided interface (cooling tower)	DN125 (nominal size 139.7-ISO 2852)	
15	Provided interface (heating & plate exchanger interface)	DN100 (GB/T 9119-2010 PN16 DN100)	
16	Flow rate (m ³ /h)	≥85	
Dry wet tower			
1	Type	Dry wet tower	
2	External dimensions (L×W×H) (mm)	6058×2438×2896	Excluding cage ladder
3	Heat dissipation capacity (kW)	1000	
4	Operating water temperature	35°C±1°C	@Wet-bulb temperature =28°C
5	Box certification	China Classification Society Certification	
6	Safety certification	NFPA 79:2021 UL 508A:2018 R8.21 CSA C22.2 No. 14-18 ANSI/ISO 12100:2012	
7	Operating power (kW)	14~28	
8	Transport weight (T)	7	
9	Operating weight (T)	12	
10	Provided interface (container)	DN125 (nominal size 139.7-ISO 2852)	
11	Water supply pipe interface	DN40 (internal thread)	
12	Drainage pipe interface	DN65 (internal thread)	
13	Noise@25°C, 15m	70dBA	

5 ANTSPACE HK3 V6 Container Water Cooling System Structural Views

5.1 External View of Container Water Cooling System

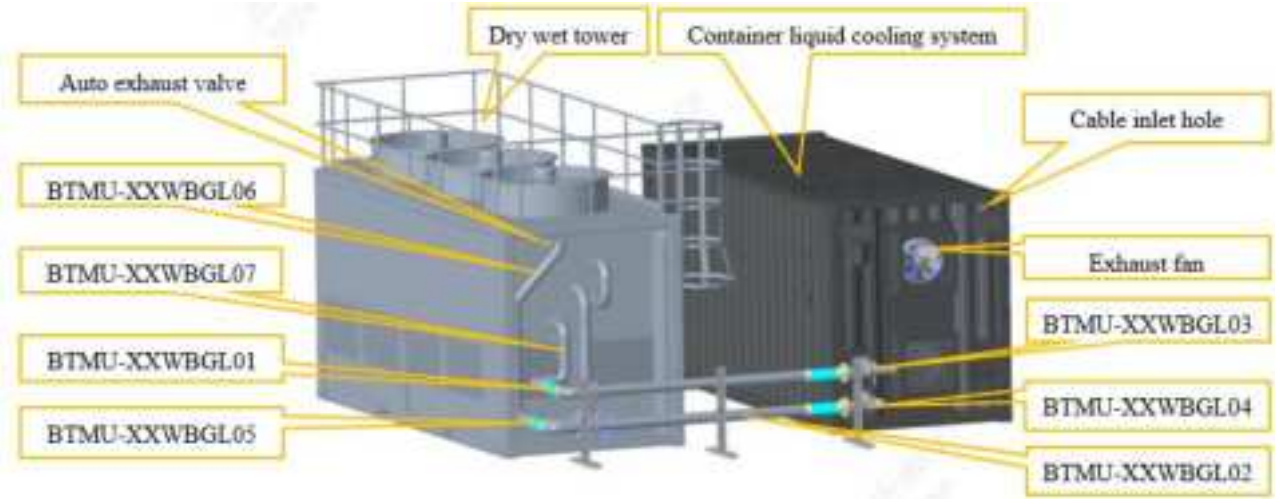

Figure 5-1 External view of container Water cooling system

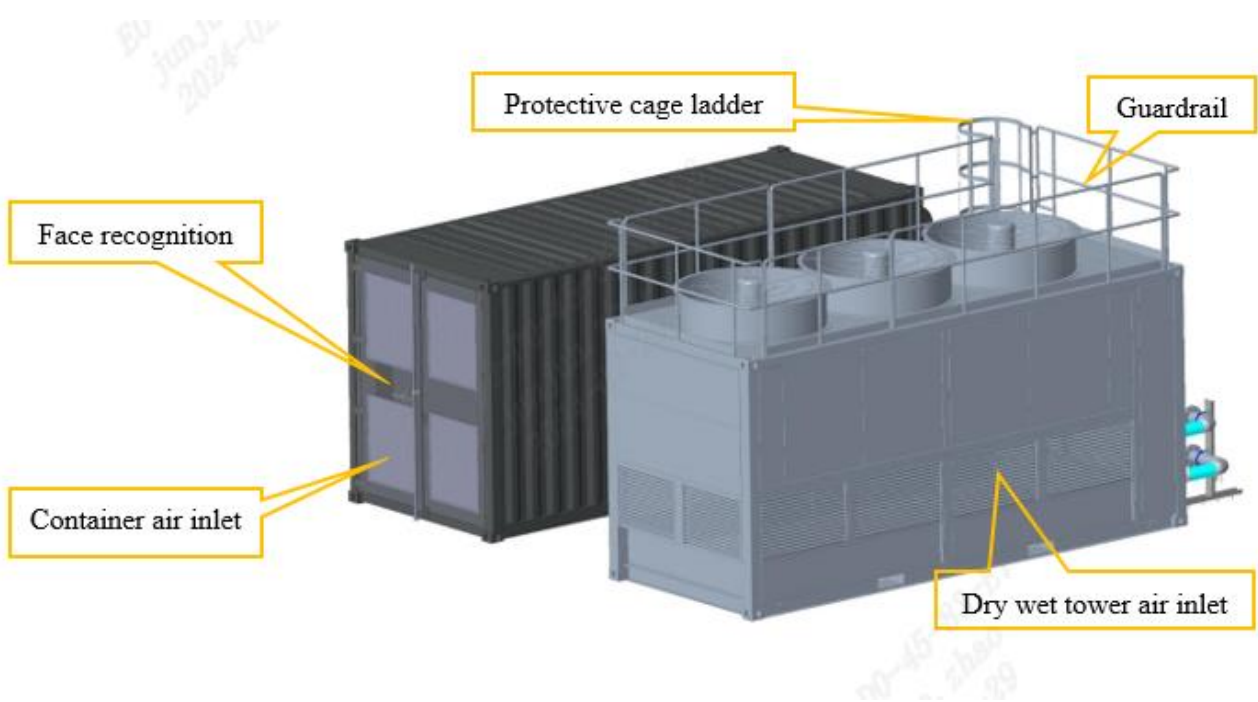

Figure 5-2 External view of container Water cooling system

5.2 Internal View of Container Water Cooling System

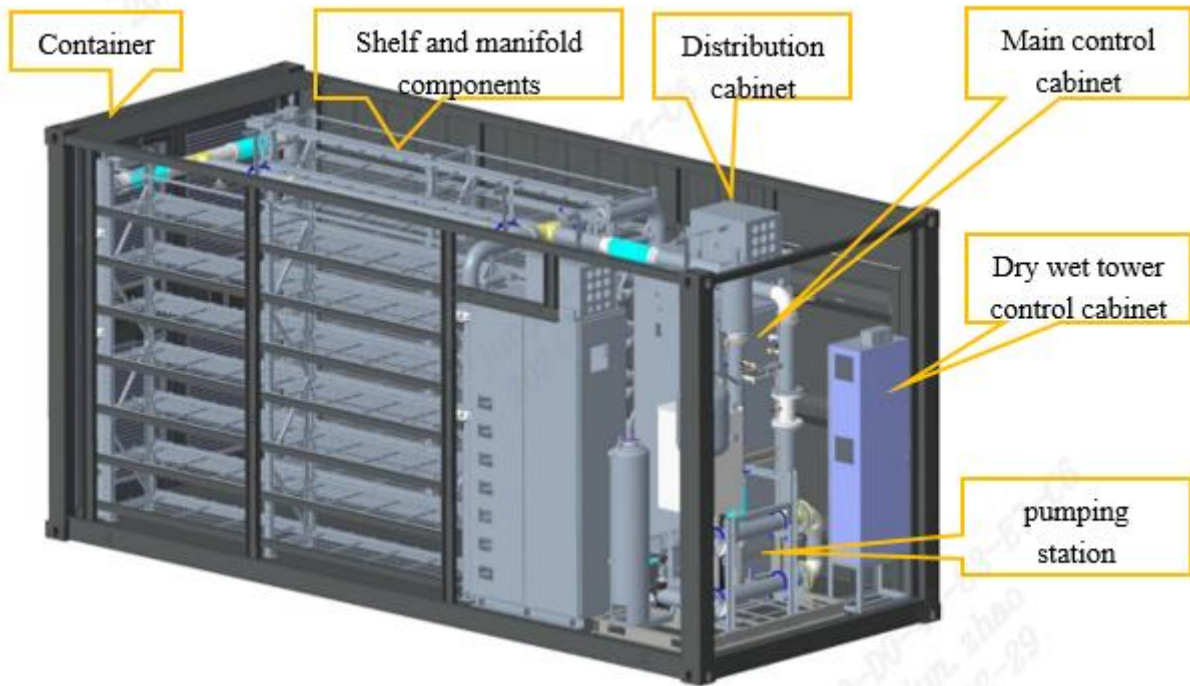

Figure 5-3 Internal view of container



Figure 5-4 Internal view of manifold components

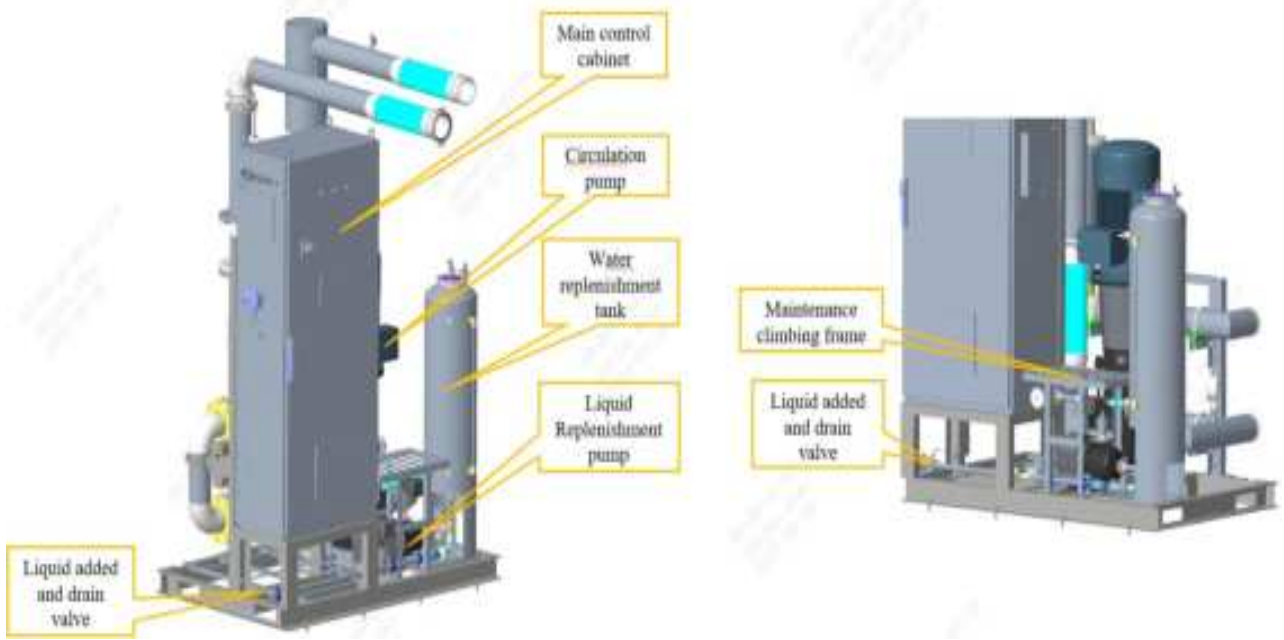

Figure 5-5 Internal view of pumping station

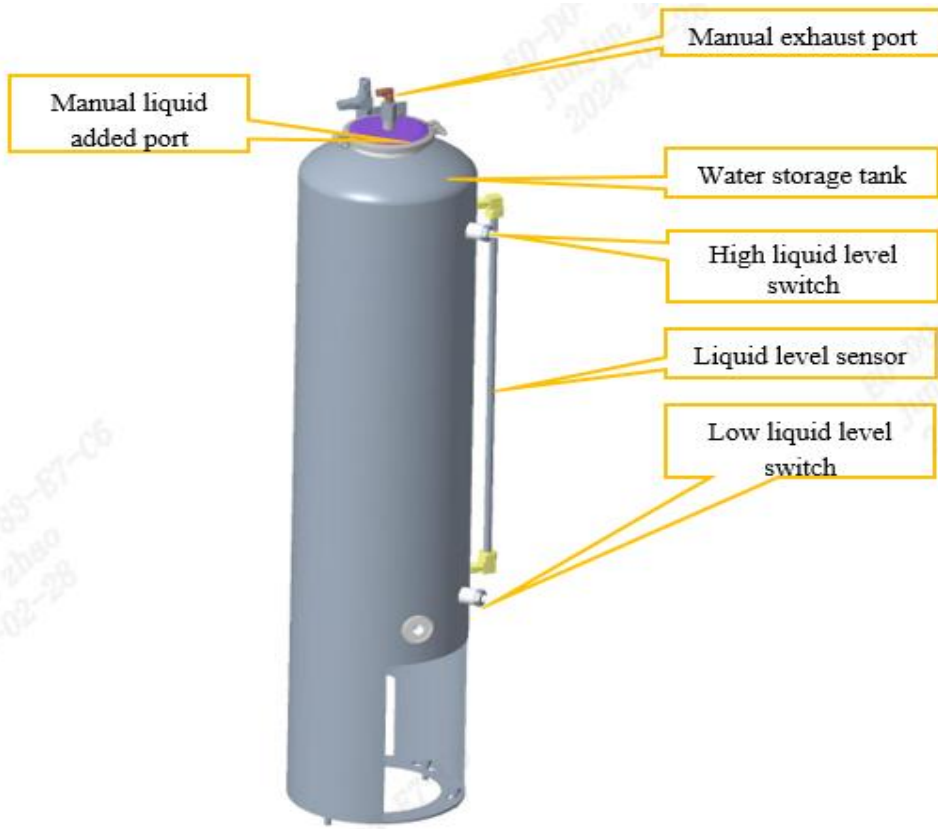

Figure 5-6 Water storage tank

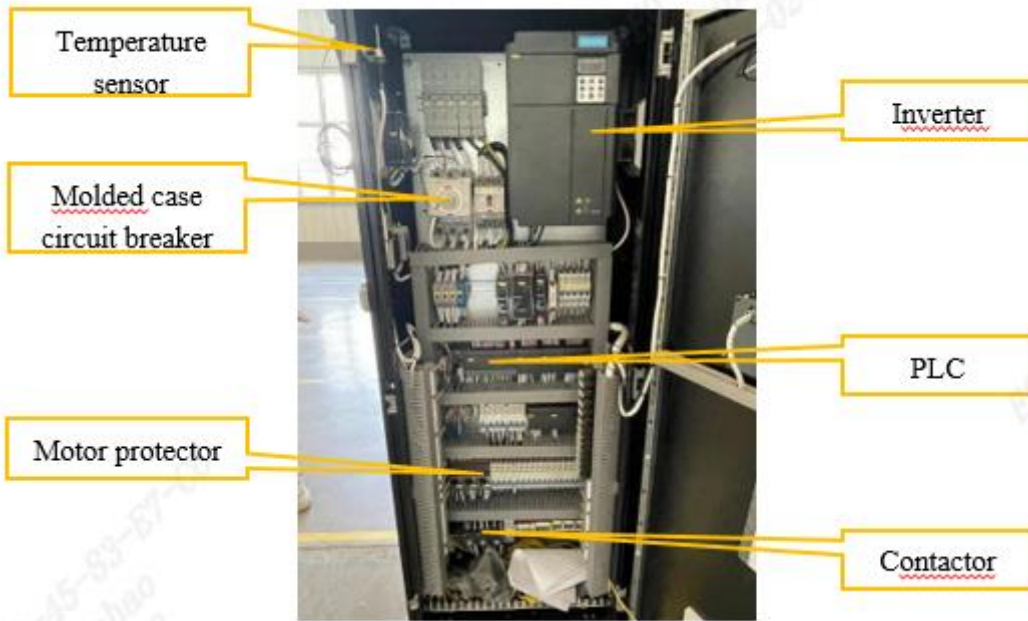

Figure 5-7 Internal view of main control cabinet

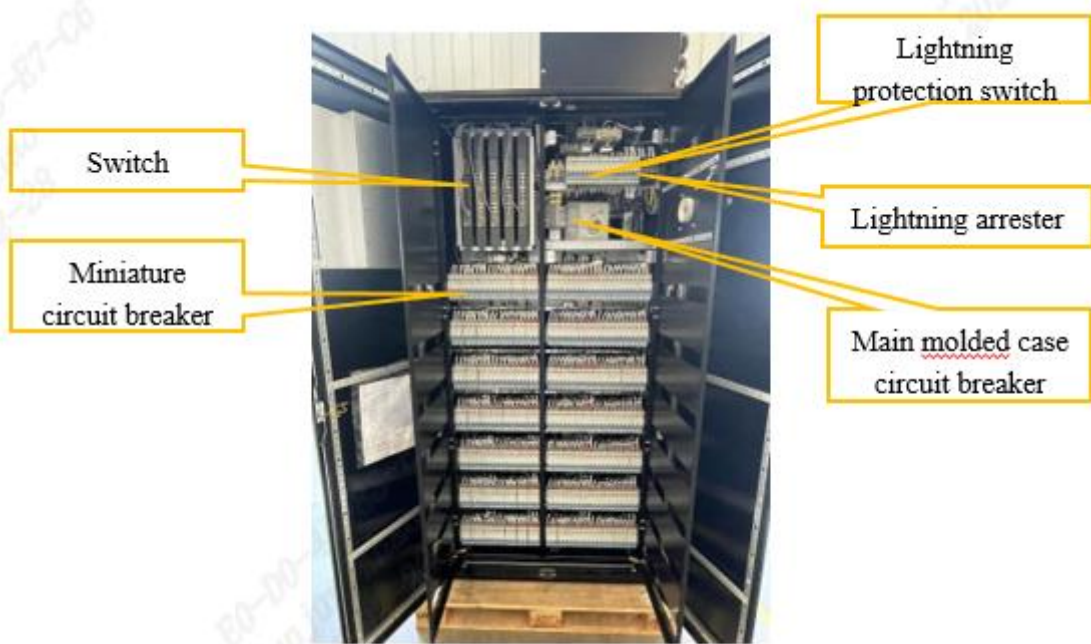

Figure 5-8 Internal view of distribution cabinet

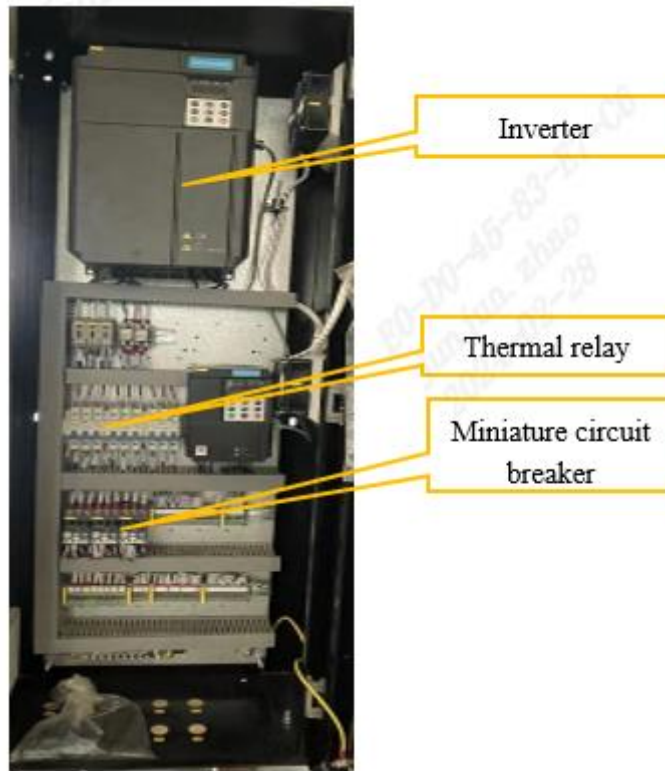

Figure 5-9 Internal view of cold tower control cabinet

6 ANTSPACE HK3V6 Container Water Cooling System Composition

6.1 ANTSPACE HK3V6 Container Water Cooling System Composition

The ANTSPACE HK3 V6 container Water cooling system mainly consists of containers, cooling towers, intermediate connecting pipelines, and other related components, as shown in Figure 6-1 Water cooling system composition. Its functions are shown in

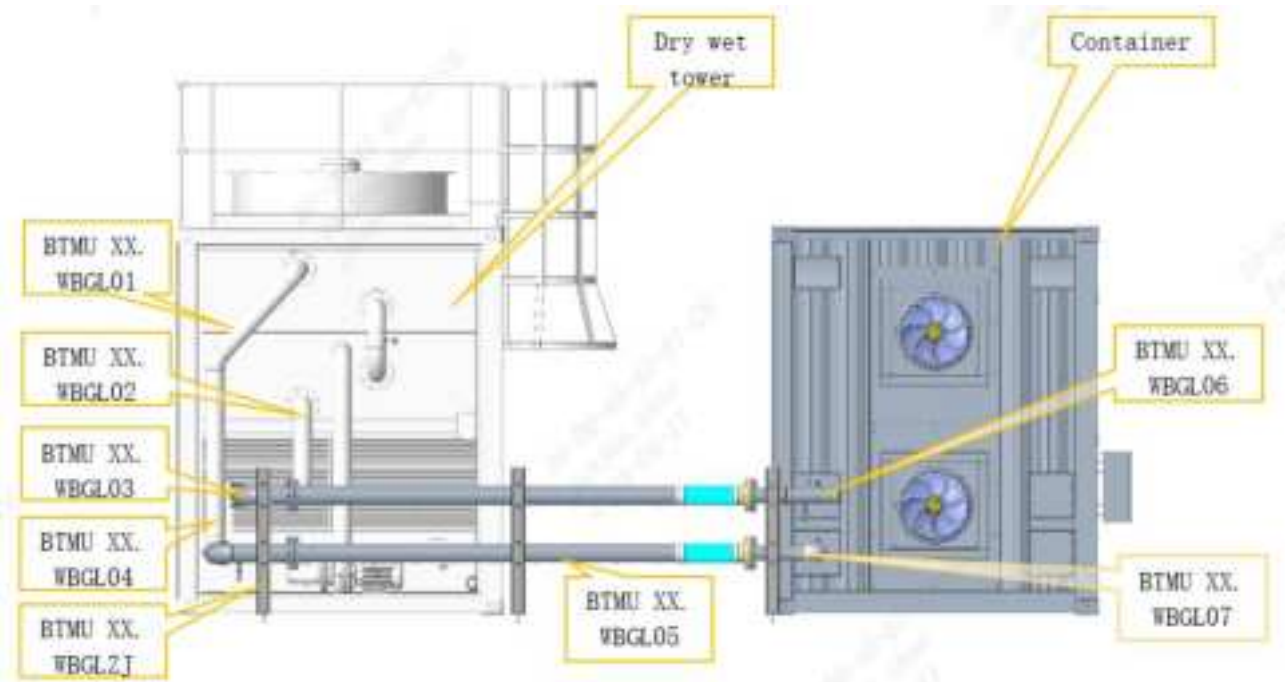

Figure 6-1 Water cooling system composition

Table 6-1.

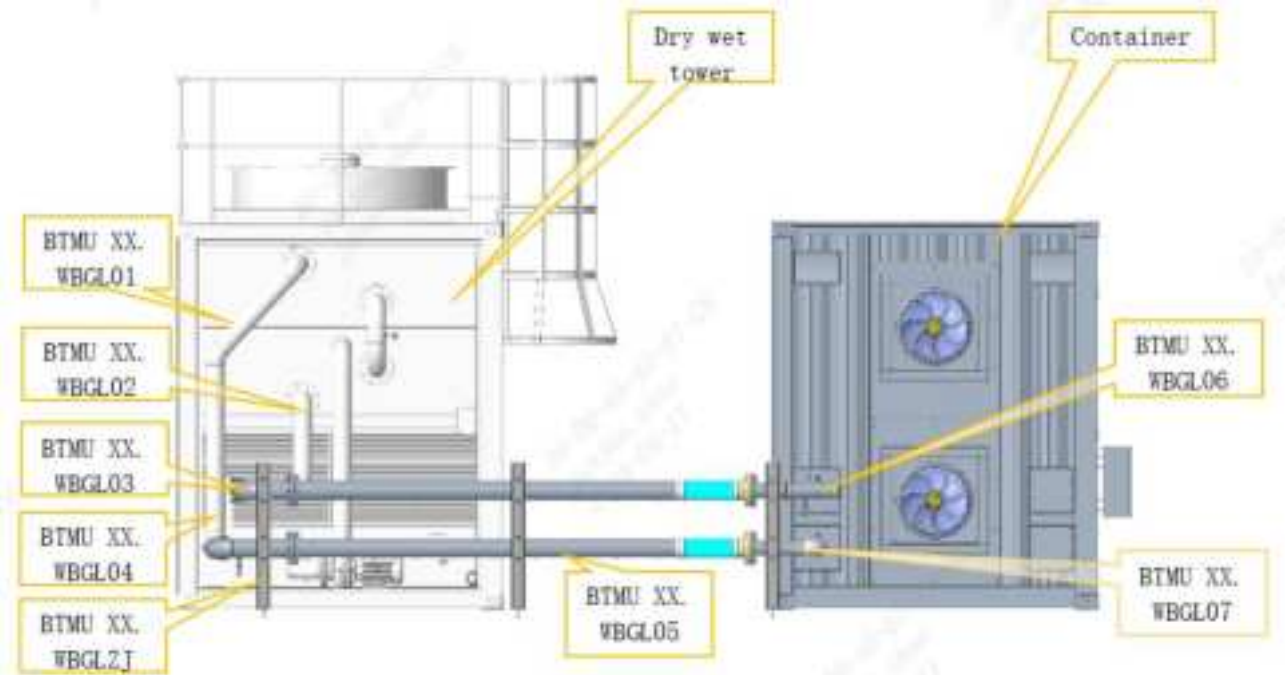

Figure 6-1 Water cooling system composition

Table 6-1 Functional description of components

SN	Module	Function	Remarks
1	Cooling tower	Heat exchange unit, which exchanges heat between the heated coolant and the atmosphere, and then transports it to the container after cooling down.	1 set
2	Container	The container includes pump sets, distribution cabinets, water distributors, shelves, etc., used to distribute water, electricity, and power to the mining machine.	1 set
3	BTMU XX.WBGL01	Dry wet tower inlet water pipeline.	1 PCS
4	BTMU XX.WBGL02	Connect the dry wet tower and container	2 PCS
5	BTMU XX.WBGL03	Container inlet water pipeline.	1 PCS
6	BTMU XX.WBGL04	Container outlet water pipeline.	1 PCS
7	BTMU XX.WBGL05	Dry wet tower outlet water pipeline.	1 PCS
8	BTMU XX.WBGL06	Dry wet tower outlet water pipeline.	1 PCS
9	BTMU XX.WBGL07	Dry wet tower inlet water pipeline.	1 PCS
10	BTMU XX.WBGLZJ	External pipeline fixing bracket.	3 PCS

6.2 Installation and Connection of Container Water Cooling and Cooling Tower

Place the container on the ground with a certain bearing strength (capable of bearing a weight of 25 tons and a ground level of $\pm 1^\circ$). The cooling tower is installed on the side of the container, and the distance between them is required to be 2 m. The cooling tower, container, and connecting pipelines are installed on site as shown in Figure 6-2.

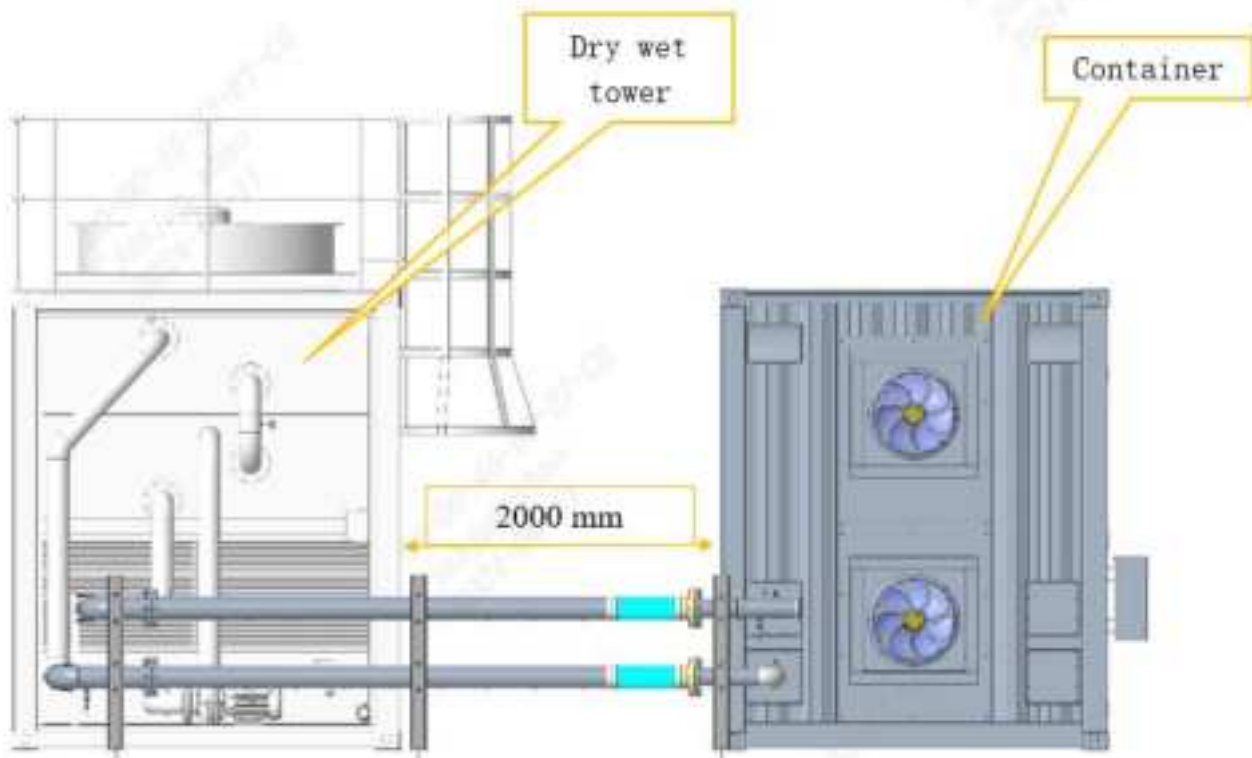

Figure 6-2 Location of container and cooling tower

6.3 Installing Exhaust Fans for Container Water Cooling

After determining the relative position of the container and the cooling tower, take out the container exhaust fan assembly (exhaust fans G04&G05, louvers, and insect proof nets are integrated, as shown in Figure 6-3 (b) from the container accessories wooden box, unpack it and perform installation:

- a) Installed at the rear door of the container, as shown in Figure 6-3 (b).
- b) Remove the protective sealing plate on the rear door.
- c) Secure the fan assembly as a whole to the rear door using bolts (M10 outer hexagonal bolts).

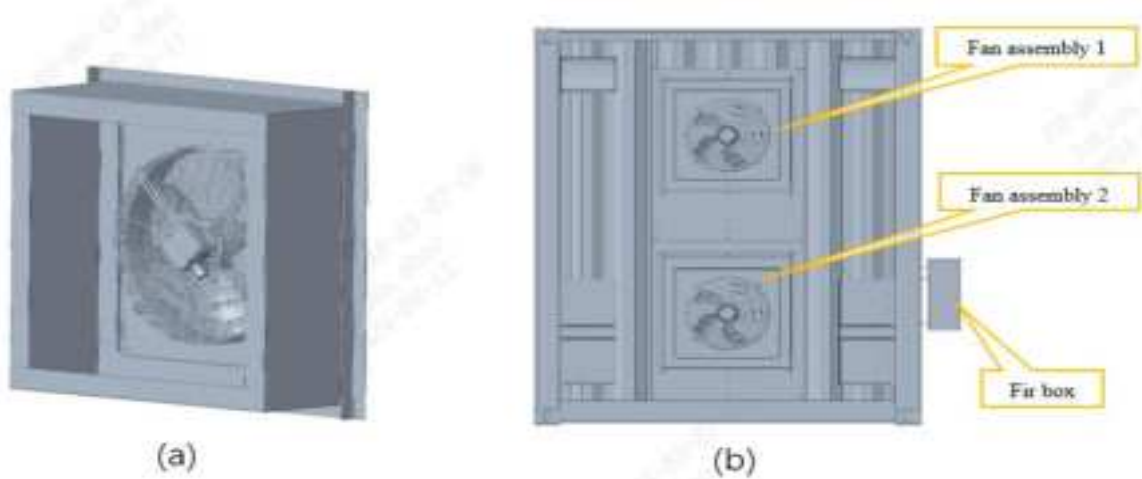

Figure 6-3 (a) Schematic diagram of fan assembly (b) Installation diagram of container fans

6.4 Container Water Cooling System Pipeline Connection

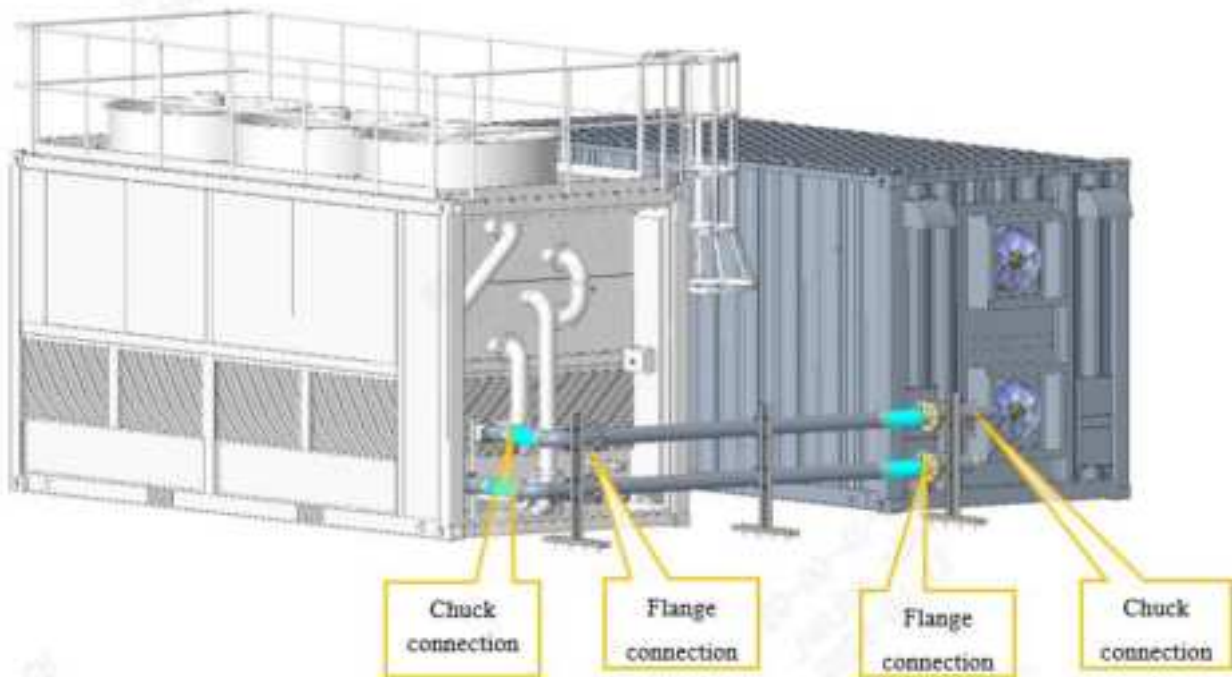

Figure 6-4 Installation diagram of external pipelines

1) Pipeline connection:

- a) Firstly, take out six pipelines numbered "BTMU XX-WBGL01", "BTMU XX-WBGL02", "BTMU XX-WBGL03", "BTMU XX-WBGL04", "BTMU XX-WBGL05", "BTMU XX-WBGL06", "BTMU XX-WBGL07", "BTMU XX-WBGLZJ" and three sets of pipeline fixing brackets from the wooden box. Then, take out the flange sealing gasket, chuck gasket,

connecting bolt (M16×75), high-pressure clamps (ISO 114.3 and ISO 141.3) and U-shaped clamp components and other accessories.

- b) Find two water supply and return pipelines (with an outer diameter of 114.3) in the container, labeled as BTMU XX WBGL03 (with filter Z01) and BTMU XX WBGL04. Connect the pipelines to the two water supply and return ports with high-pressure clamps (ISO 114.3/304/PN16) in combination with the chuck sealing gasket (ISO 114.3). It should be noted that the sealing gasket should not be damaged, worn, or deformed. External pipeline 03 (BTMUXX WBGL03) is connected to the inlet of the container system on the upper side, and BTMUXX WBGL04 is connected to the outlet of the container system on the lower side. After the connection is completed, fix them with a pipeline bracket and a DN100 U-shaped clamp.
- c) Connect the above pipelines according to the requirements in Figure 6-4. There are 10 connections in total: 6 flange connections, 8 single connection points, and 1 DN125 sealing gasket is required for each connection; 4 chuck connections, 1 connection point at a single location, and 1 ISO 141.3 chuck sealing gasket is required for each connection. It should be noted that the sealing gasket should not be damaged, worn, or deformed.

 **Caution**

After the pipeline is connected, please check whether the filter Z01 screen of the external pipeline 06 is intact.

2) Fixed pipelines and external pipeline brackets

After connecting the intermediate pipeline, it is necessary to fix the pipeline and external pipeline bracket:

- a) Fix the external pipeline bracket.

The pipeline needs to be tightly attached to the bracket for fastening. The external pipeline bracket is fixed to the ground using expansion screws (M12 * 80), and the ground needs to be drilled in advance using an electric drill.

- b) Use U-shaped pipeline clamps (DN125/M12/304) to secure the pipeline to the external pipeline bracket.
- c) Check if the connection points are loose and mark all threaded connection points with a line (black and blue double marking is recommended).

7 ANTSPACE HK3 V6 Container Water Cooling System Use and Operation

7.1 Safety Rules

1) Hazard level

Danger

 Inside the device is a live label, and it is prohibited to open protective panels with live labels. Even in case of power outage, non professionals are prohibited from opening the cover plate.

2) Precautions for Use

- a) Filtered coolant should be used as the cooling medium, and there should be no floating or particulate matter in the supply circulation system.

Warning

The cooling medium should be produced by a reputable manufacturer and should not be mixed by oneself. Otherwise, we will not be responsible for any problems that may arise. It is recommended to use organic cooling liquid (inorganic cooling liquid contain P, Si, B, Mo, nitrate, etc., which can generate sediment over time). Recommended manufacturers of cooling liquid include Great Wall, Shell, etc. The coolant model is selected based on the minimum temperature of the project location.

Warning

It is prohibited to add tap water or exceed the specified coolant in the system. The system operation should have regular monitoring of the coolant. Once the coolant properties change, a new coolant must be replaced.

- b) When the ambient temperature is below 0°C, the water in the collection tank and spray pipeline must be completely drained to prevent freezing and damage to the equipment.
- c) Equipment should avoid wiring midway and is strictly prohibited from being used in parallel with other equipment.
- d) If there are any abnormalities in the equipment (such as stink, etc.), it should be shut down, disconnected from the power supply, and inspected.
- e) There are emergency stops on the entrance doors and container doors of distribution cabinets A and B. When an emergency occurs, pressing the emergency stop will immediately disconnect the power circuit breaker. After an emergency reset, first turn the main circuit breaker to the **OFF** position and then power on again.

Warning

All emergency stop buttons used in this system are rotary release type. After the emergency stop button is pressed and confirmed and confirming that the system is functioning properly, it is necessary to rotate the emergency stop button clockwise to release it. Then, the main switch of the distribution cabinet and the main control cabinet can be closed. Before closing the switch, it needs to be turned to the OFF position and then re-closed.

- f) Circuit breaker MCB-A1 can only cut off power to distribution cabinet A.
- g) Circuit breaker MCB-A2 can only cut off power to distribution cabinet B.

Danger

The silk screen on the inner door of the power distribution cabinet indicates which switches are still live after the main switch is powered off. Please read carefully before operation. Avoid causing electric shock accidents.



Figure 7-1 (a) Emergency stop knobs on the front door

(b) Location of MCB-A1/A2

- h) The circuit breaker QFWCU can only power off the main control cabinet.
- i) To prevent danger, when repairing a single high computing power server, the power switch corresponding to the serial number of the high computing power server in the distribution cabinet must be disconnected, and then the power interface, network cable interface, and water supply interface of the corresponding high computing power server must be unplugged. Finally, the power source of the high computing power server must be unplugged to repair the high computing power server. If it is necessary to power off the entire container equipment, the steps are as follows:
 - Firstly, disconnect the micro circuit breakers of 210 high computing power servers.
 - After an interval of 10 seconds, disconnect the main power supply of the main control cabinet.

- Then disconnect the main switches of the two distribution cabinets.

⚠ Caution

Since the container lighting circuit is led out from the main control cabinet, if you want to perform the above operation, please bring a portable lighting tool.

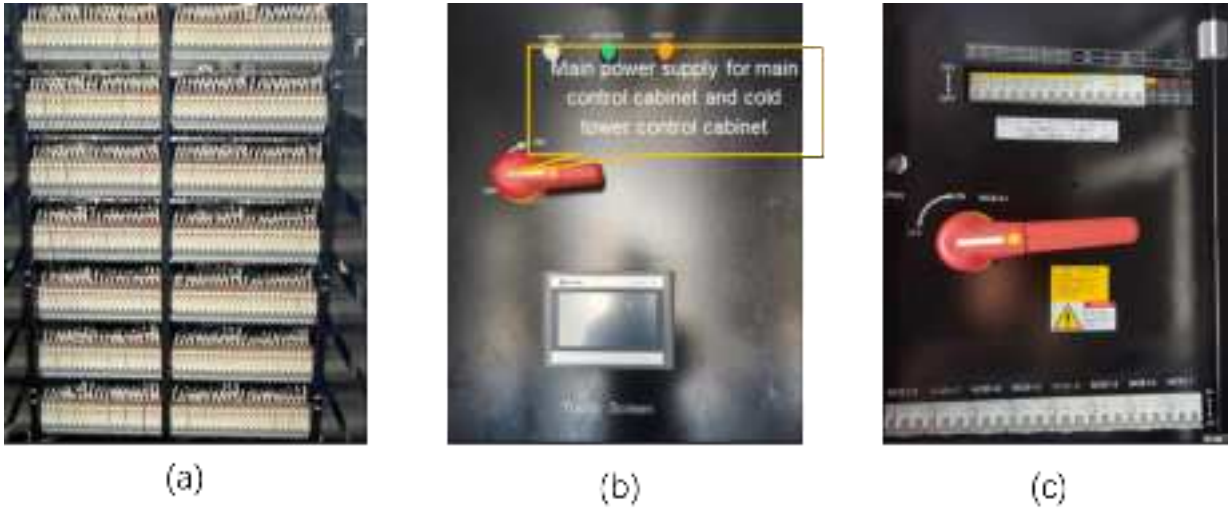

Figure 7-2 (a) Distribution cabinet circuit breakers (b)Internal of the main control cabinet (c)The main circuit breaker of the distribution cabinet

If necessary, also disconnect the main switch at the transformer end. Remember to strictly follow the above requirements for the closing sequence of switches.

- j) It is strictly prohibited to open the protective cover on the fan.
- k) It is strictly prohibited to touch the fan blades directly to test whether the fan is rotating, or to rotate the fan blades by hand.
- l) It is prohibited to operate the equipment with wet hands, otherwise it may cause electric shock accidents. It is prohibited to put debris inside the equipment to ensure that the fire passage is always unobstructed.

⚠ Warning

If the device is not working for a long time, please disconnect the main power supply.

7.2 System Pressurization

After the on-site installation of equipment and pipelines is completed, a **7 bar** air pressure test should be conducted first, with the pressure maintained for at least 12 hours. Then conduct a **7 bar** water pressure test, with the pressure maintained for at least 30 minutes. Check if there is any

leakage in each pipeline and interface. If there is no leakage and the pressure reading decreases by less than 5%, it indicates that the on-site installation inspection is qualified. The pressurization process is as follows:

1) Preparation Before Pressurization

- a) Prepare hoses and air pumps (recommended brand: OUTSTANDING, model 2200W-40L. Selection basis: the internal volume of the system is about 1.5 m³, and the air pump with corresponding exhaust volume is selected according to time requirements; the maximum output air pressure is required to be above 8 bar, and 10 bar is optimal);
- b) Connect the external pipelines according to the previous chapters.
- c) Check if all the plugs on the automatic exhaust valves on the internal and external connection pipelines of the container are closed. Automatic exhaust valves include V302&V303 on the water distributor 7, V301 on the degassing tank, V304 on the expansion tank, manual exhaust valve V701, and cooling tower exhaust valve V306. By screwing the top nut of the automatic exhaust valve, the automatic exhaust valve can be opened/closed.
- d) Check whether the safety valve ball valve V410 and expansion tank ball valve V105 are closed, and check whether each Water filling and drain valve is closed. The water distributor has 4 drain valves (V205-V208), the pump station has 1 filling/drain valve (V104), 1 drain valve (V201), and 1 filling valve (V209).

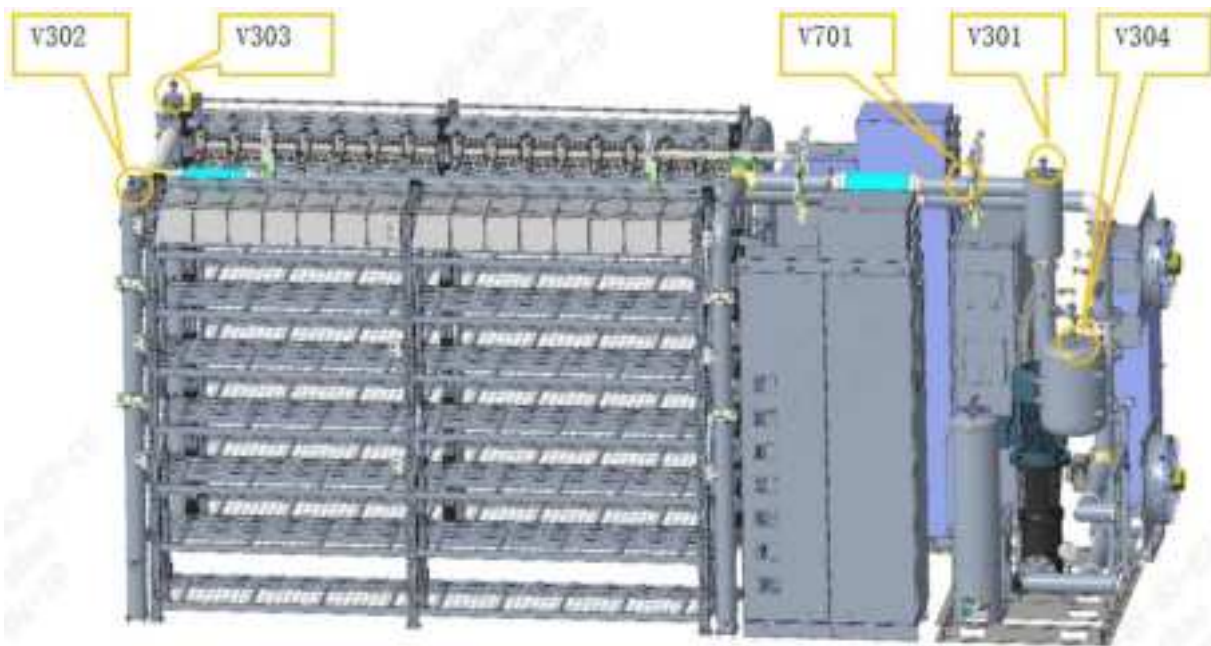

Figure 7-3 Location of the exhaust valve in container system

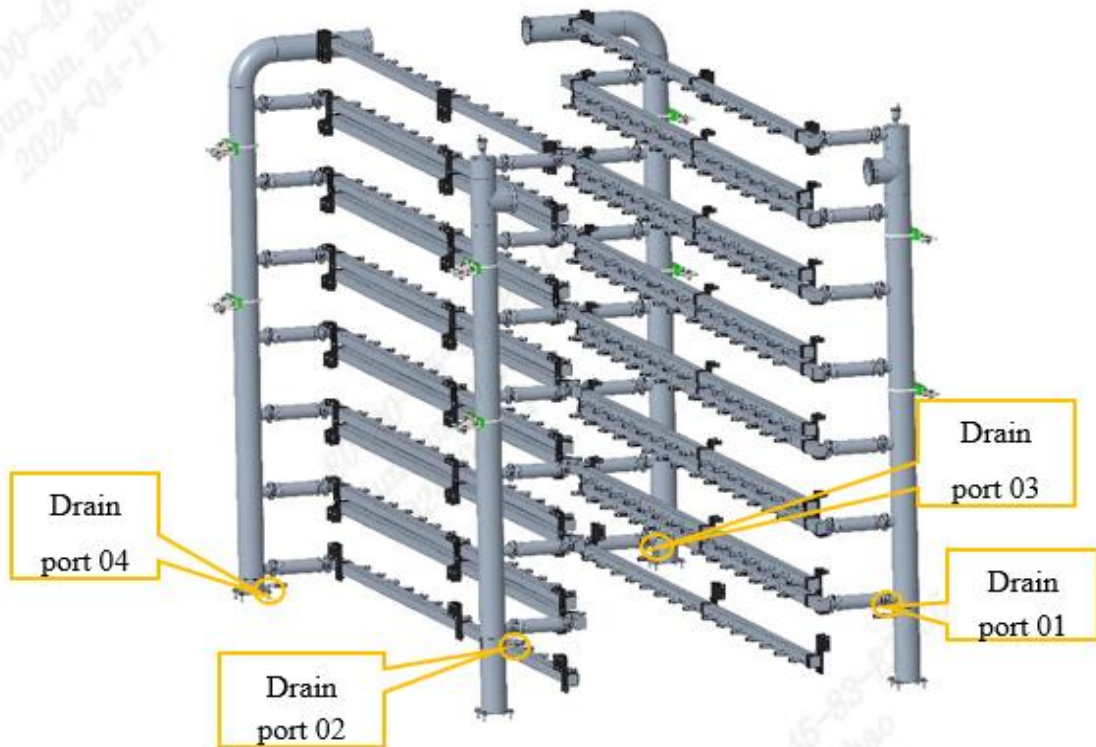

Figure 7-4 Water distributor drain port

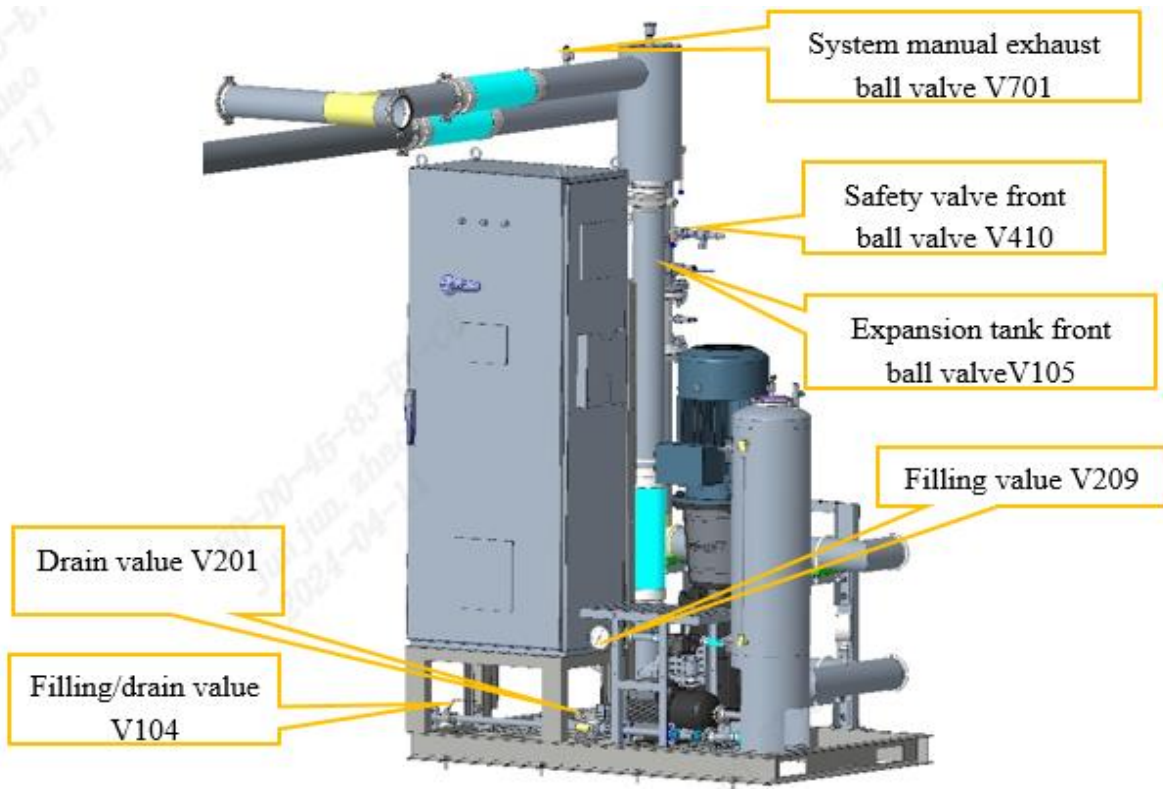

Figure 7-5 Schematic diagram of pump station valves

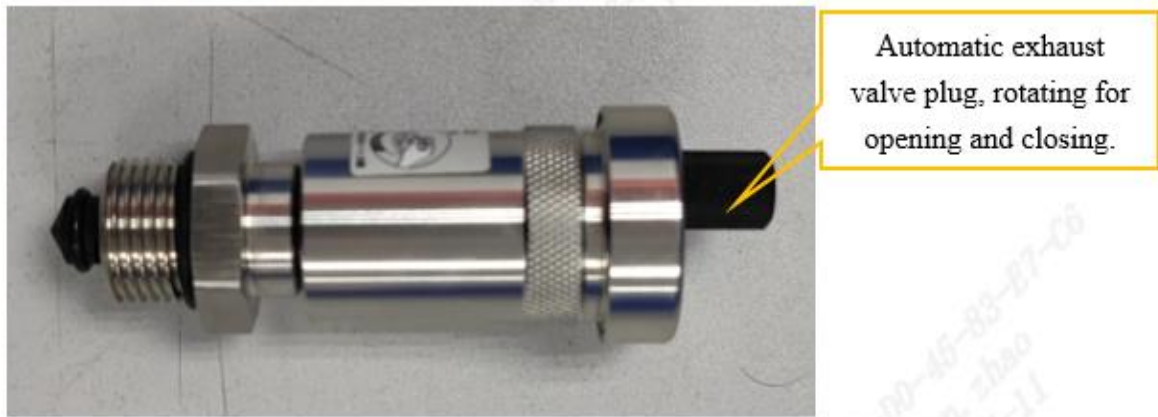

Figure 7-6 Automatic exhaust valve



Figure 7-7 Schematic diagram of valve opening and closing

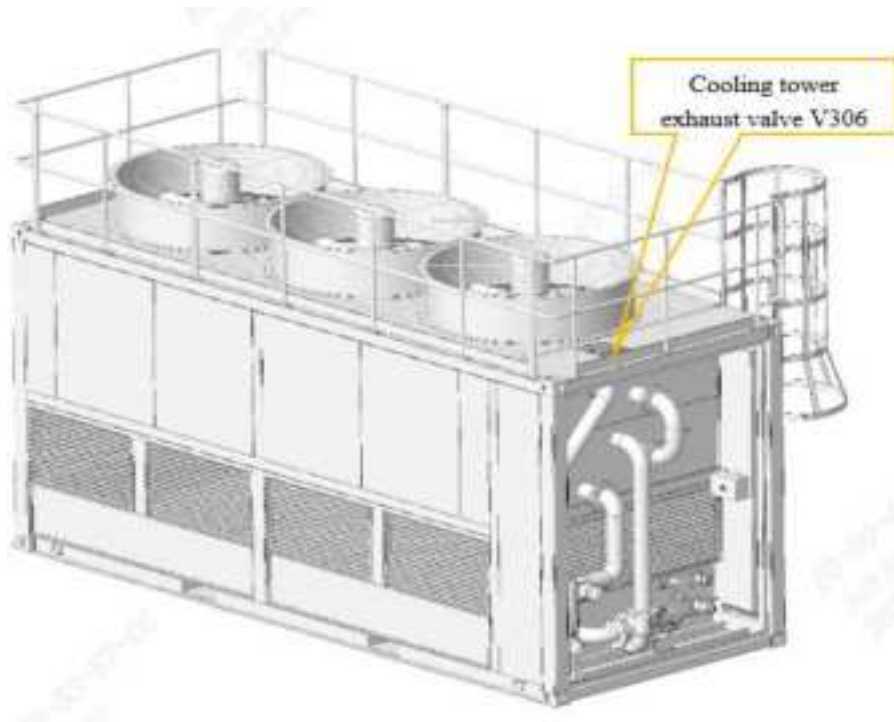

Figure 7-8 Cooling tower exhaust valve position

2) Pressurization Steps

- a) Check again that the exhaust valve plugs and ball valves are closed.
- b) Close the filling/drain ball valve V104, the expansion tank front valve V105, and the safety valve front valve V410, as shown in Figure 7-7 Schematic diagram of valve opening and closing
- c) .
- d) Open all mini ball valves on the water distributor.
- e) Connect to any quick connection port with the air pipe and close the corresponding ball valve of this circuit.

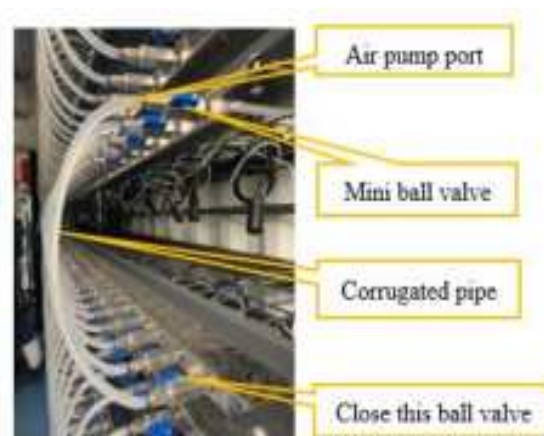

Figure 7-9 System pipeline connection ball valve

- a) Use an air compressor to pressurize to 7 bar and stabilize for more than 12 hours, and check for any leakage points.
- b) The key inspection.

The key inspection areas are as follows:

- a) The connection between the quick connector and the mini ball valve.
- b) The connection between the quick connection ball valve and corrugated pipes.
- c) The connection between the mini ball valve and the water distributor.
- d) The connection between the quick connector and computing power server.
- e) Each flange/chuck/threaded/welded connection.

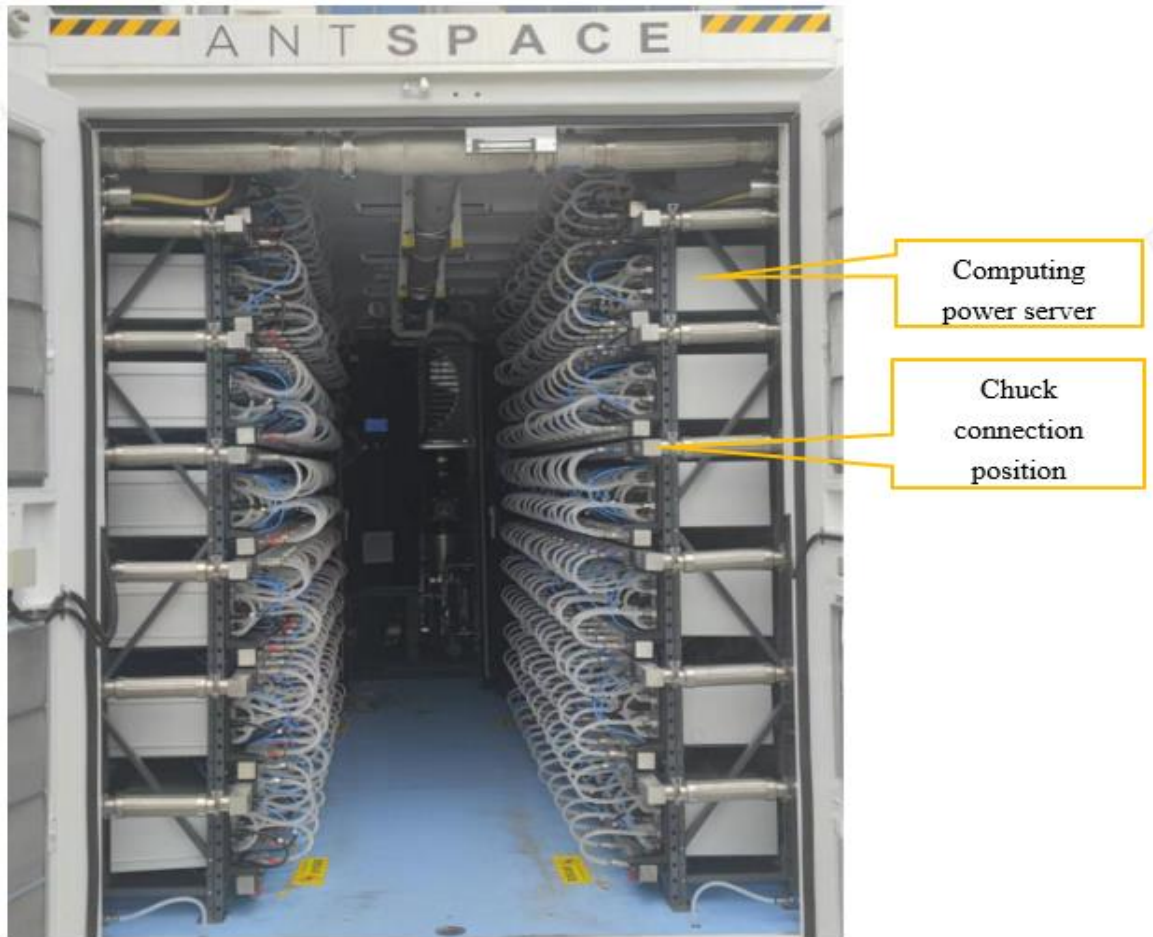

Figure 7-10 System chuck connection

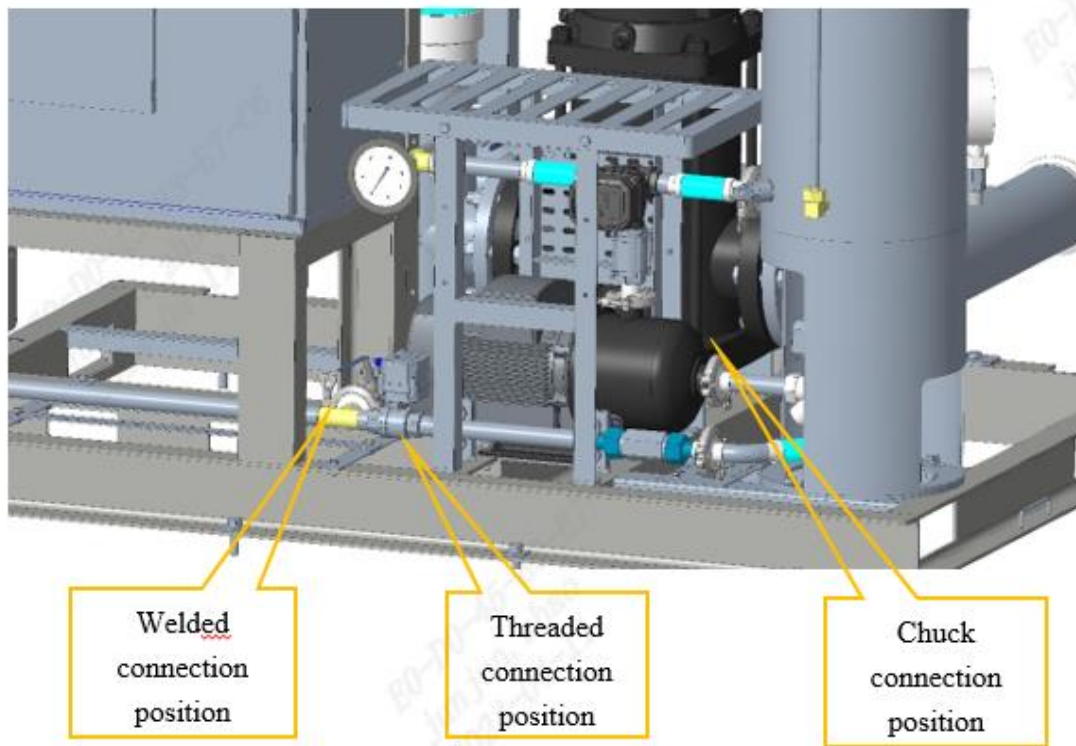

Figure 7-11 System leakage point inspection

The inspection method is as follows:

- Check for leaks by seeing, listening and touching.
- Add water to one of soap, laundry detergent, and detergent to make soap solution, and apply it to suspected leakage points, especially at the joints. The areas with bubbles and bulges are the leakage points.

7.3 System Water Replenishment

During the installation of the external pipeline, it is necessary to check whether the filter Z01 in the external pipeline 06 is intact.

The spray water inside the cooling tower adopts tap water or softened water, and a tap water pipe (DN40) is installed on site. It is recommended to choose appropriate antifreeze or purified water based on local climate conditions as the circulating media in cooling tower and container.

Firstly, add Water to the system with a Water filling pump. When the return pressure reaches the required value, stop adding Water to the system. Switch the pipeline switch, and start the Water filling pump to add Water to the water tank. When the Water level in the water tank reaches the required height, switch the pipeline switch, and the system will automatically run.

The specific Water filling procedure is as follows:

- Preparation: Prepare materials and tools, and open all exhaust valves of the system (open the manual exhaust valve of the system and the manual exhaust valve on the cooling tower for the first Water filling).
- System Water replenishment: Replenish the system with Water filling pump P11.

- c) Water tank replenishment: Replenish the water tank with Water filling pump P11.
- d) Regular replenishment of water tank: Replenish the water tank with the Water filling pump P11 or through the manual filling port on the top of the water tank.

1) Preparation

- a) Prepare the coolant.
- b) Connect the external pipeline according to the previous chapters.
- c) Check if all the plugs on the automatic exhaust valves on the internal and external connecting pipelines of the container are open (see **错误!未找到引用源。** and Figure 7-7 Schematic diagram of valve opening and closing
- d)).
- e) Open the filling valve V209 and close the drain valve V201 (see

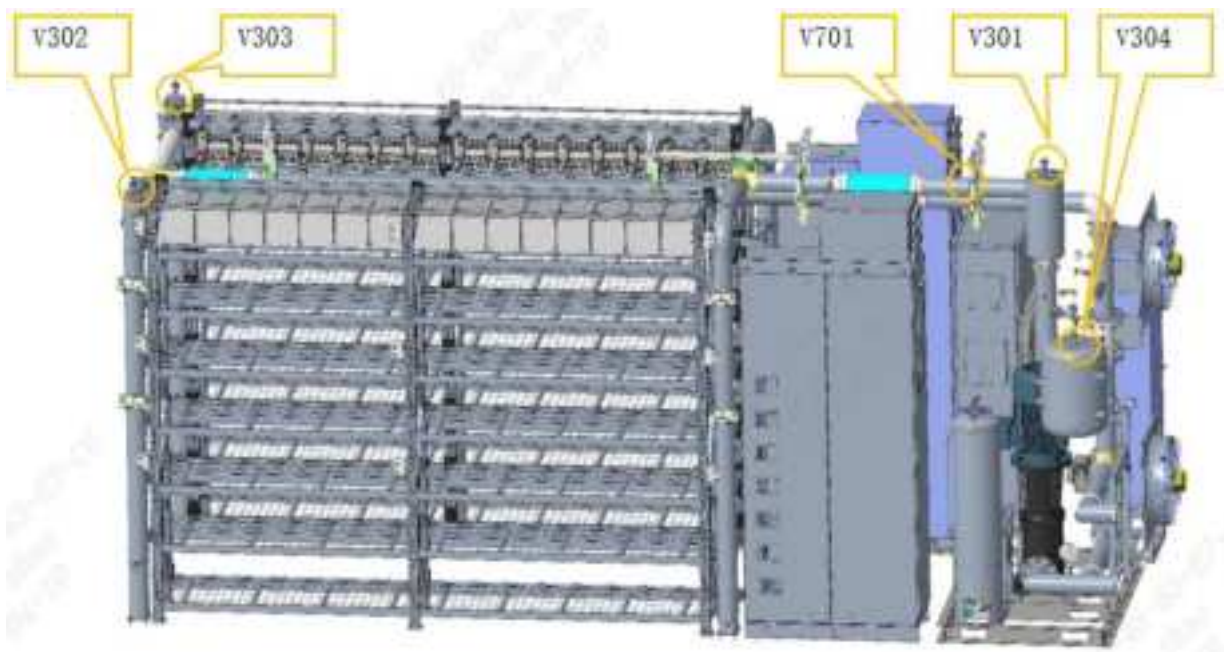

f) Figure 7-3 Location of the exhaust valve in container system

g) and Figure 7-4 Water distributor drain port

h)).

i) Open the exhaust ball valve V702 on the top of the water tank to ensure that the water tank is connected to atmospheric pressure (as shown in Figure 7-12).

j) Open the manual exhaust valve V701 of the system and connect the PU pipe to the quick connector on the water tank (to accelerate the first Water filling).

- k) Switch the exhaust valve of the cooling tower to the manual exhaust valve (as shown in Figure 7-12 Water tank valve
- d)).



Figure 7-12 Water tank valve



Figure 7-13 Cooling tower exhaust valve

2) System and Water Tank Replenishment

- a) Replenish the system and water tank C21 with the Water filling pump P11.
- b) Find an external water source (with a certain pressure), and connect the hose to Water filling/drain port V104 on the container. Fill the connecting pipeline with Water for the first Water filling (until water flows out). Find the Water filling port outside the container and plug in the hose (at the side door of the container). Then, connect the external water tank to the Water filling pump P11.
- c) Open the exhaust valve of the Water filling pump (Allen wrench), switch to manual mode on the touch screen, and open the solenoid valve V202. After water is discharged, close the manual exhaust valve of the Water filling pump.
- d) Close solenoid valve V202, switch to manual mode on the touch screen, and open the "Manual Water Replenishment" mode "External → System" of the Water filling system, which means adding Water to the system. Open "External → C21", which means adding Water to the water tank C21 externally, as shown in Figure 7-14 Distribution of solenoid valves in the Water filling system
- e) .
- f) When adding Water to the system, pay attention to whether there is water flowing out of the exhaust valve of the cooling tower and the manual exhaust valve of the system. When there is water flowing out, it indicates that the system has been fully filled. Then, close the manual exhaust valve of the cooling tower, open the automatic exhaust valve, and close the manual exhaust valve 701 of the system.
- g) When the static pressure reaches 0.7 bar (refer to Figure 7-16, touch screen reading) or above, the circulation pump can be started for 10 seconds (without stopping the Water filling pump), and then the circulation pump can be stopped.
- h) Continue to add Water and repeat for twice to ensure that 1.3-1.5 tons of coolant are added.
- i) When the static pressure reaches 1.0-1.5 bar, stop adding Water (observe the reading of the main interface pressure sensor PT02, as shown in Figure 7-16).
- j) Turn on the circulation pump P01 again to circulate the coolant in the system, ensuring that all automatic exhaust valves are in open state.
- k) Due to the first Water filling and the presence of gas in the system, the discharge of gas during the water pump circulation will cause a decrease in pressure in the system. At this time, the Water filling function is turned on, and the water tank replenishes the system to ensure that the return pressure is between 1.0 and 1.5 bar.

- 1) After the above operation is completed, the system back pressure (pressure gauge PI03/return pressure sensor PT02) will be stabilized at 1-1.5 bar and for normal operation. Automatic mode can be turned on and the computing power server can be turned on for operation.

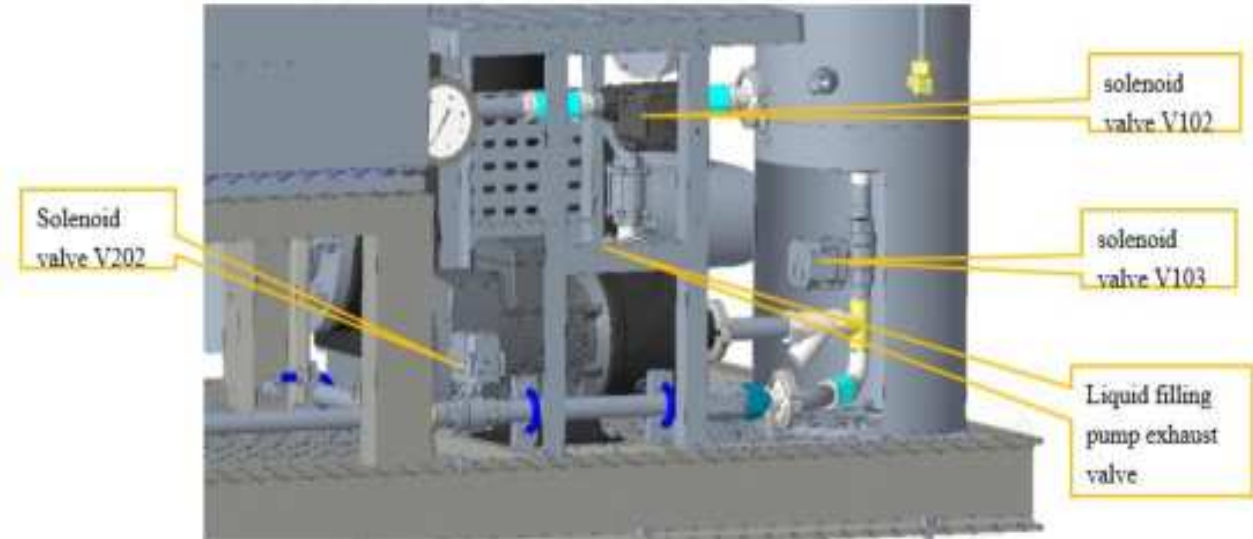

Figure 7-14 Distribution of solenoid valves in the Water filling system



Figure 7-15 Water filling system interface

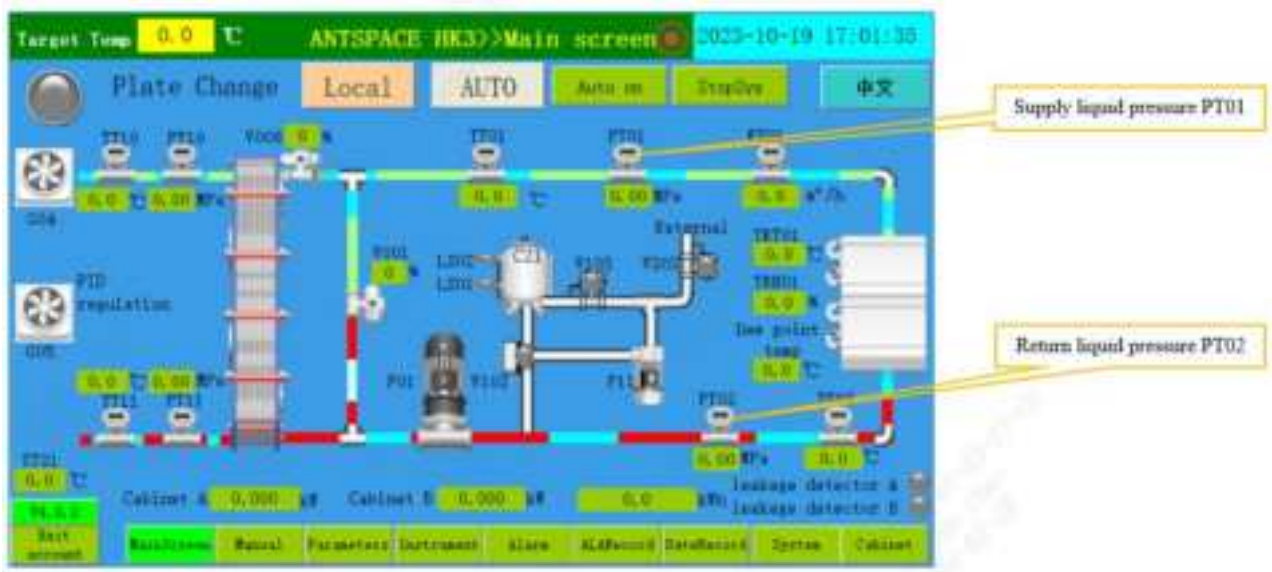

Figure 7-16 System operation interface

3) Regular Replenishment of Water Tank

When water tank C21 needs to be replenished with a small amount of coolant, the following methods can be referred to:

Method 1: Same as the first Water filling, connect the Water filling pump P11 to an external water source (with a certain pressure; fill the connecting pipeline), turn on the Water replenishment mode, and externally add Water to the water tank C21.

Method 2: open the installation chuck of the exhaust valve on the top of the water tank (refer to Figure 7-12), and manually add Water from the manual filling port to the inside of the water tank.

7.4 Electrical Wiring

The electrical system requirement for the equipment is TN-S three-phase five wire system. Due to the two distribution cabinets (A/B cabinets) inside the equipment, in order to ensure safe and stable operation of the equipment, two 500kW three-phase five wire cables (with a rated current of 1200A for the main switch) should be prepared in advance on site.

! Danger

Electrical connections must be operated by professionally qualified personnel. In addition to complying with the requirements of this manual, the operation procedures must also comply with the relevant local electrical regulations and safety regulations of the project.

Unqualified personnel are strictly prohibited from making electrical connections to the equipment.

The specifications and quantity of equipment input cables must comply with local electrical regulations. Please consult a qualified electrical engineer when necessary.

Three M16 bolts are reserved for the L1, L2, and L3 input copper bars on the top of the A/B cabinet, and the middle hole of the cable fixing terminal is specified to be 17mm in diameter. Reserve two M12 bolts for the N copper bar and reserve M12 bolts for the PE copper bar.

! Caution

The fixing torque of M16 bolts is 100N.m, and the fixing torque of M12 bolts is 80N.m, or refer to the electrical standards of the project. Be sure to ensure reliable electrical connections. .

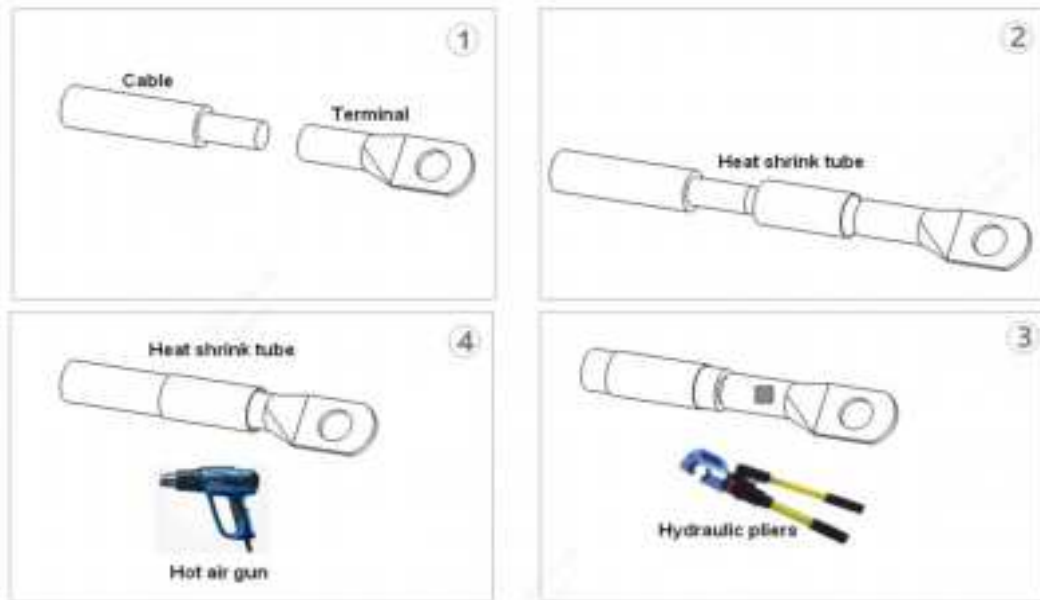

Figure 7-17 Stripping and crimping

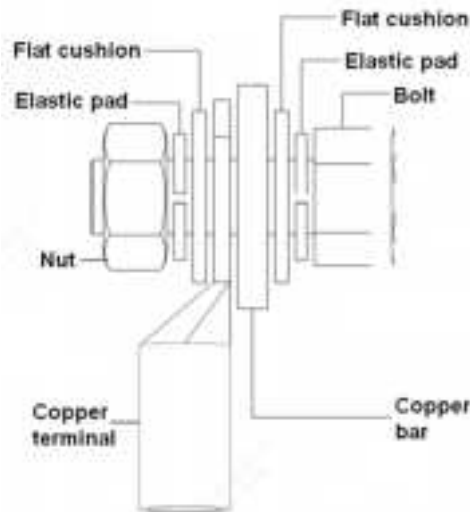

Figure 7-18 Select copper wire

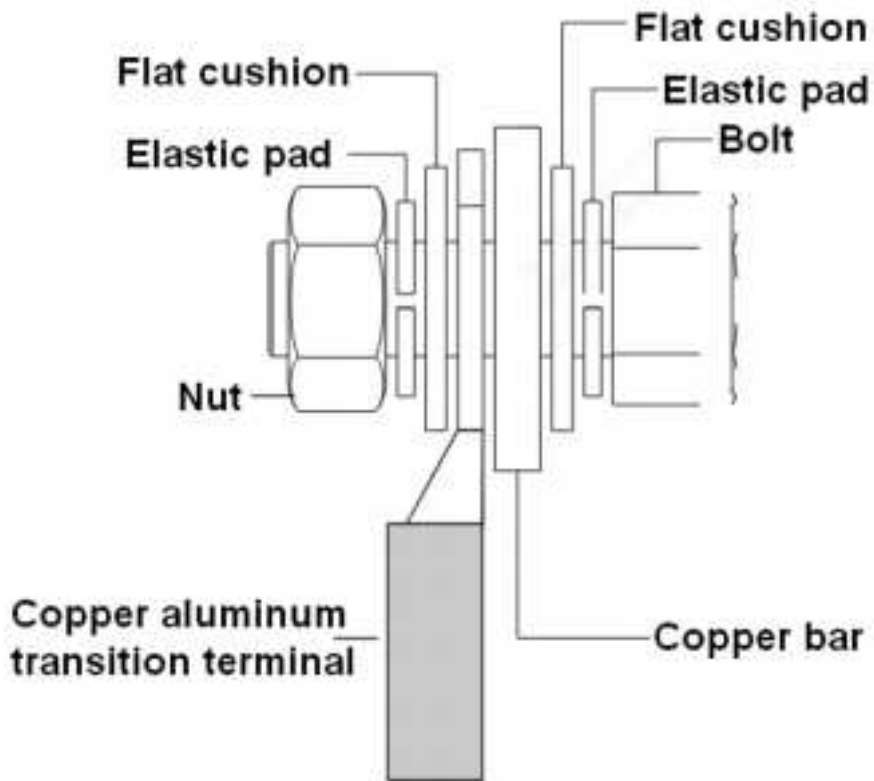

Figure 7-19 Select aluminum wire

After the wiring is completed and the bolts are fixed according to the torque, use a marking pen to mark the nut head for subsequent inspection.



Figure 7-20 Cable connection diagram

The cables are connected from the upper two openings on one side of the container exhaust fan, as shown in Figure 7-21 (note: it is necessary to use rainproof cloth and cover in the accessories for protection). The cables are connected from the top junction boxes of the two distribution cabinets and extend all the way to the corresponding copper bars. They are installed and fixed with screws (already installed at the copper bar openings).



Figure 7-21 Cable inlet holes

There are grounding studs on both sides of the container, and the distribution cabinet should also be reliably grounded. Therefore, it is chosen to reliably ground the shell of the container and the shell of the distribution cabinet. When leaving the factory, the phase sequence of the equipment has been determined. After the equipment arrives at the site, it only needs to adapt to the phase sequence of the on-site substation.

The operation is as follows: connect the L1, L2, L3, N, PE three-phase and five wires of the substation to the distribution cabinet, power on the main switch of the main control cabinet, and observe whether there is a power failure alarm on the LCD screen; If there is a power failure alarm, please adjust the phase sequence of the three phases connected to the main control cabinet L1, L2, L3; If there is no fault alarm on the LCD screen, it can operate normally.

 **Danger**

The three-phase power coming from the transformer must be connected by professionally qualified personnel. When adjusting the phase sequence, the front-end voltage at the input end of the external transformer must be powered off before operation (the white light on the front of the main control cabinet does not light up, and the input line voltage is measured with a multimeter to be 0V). It is prohibited to adjust the phase sequence while the power is on at any time.

Due to the separation of the cooling tower and container, there are also three heat dissipation fans, a spray pump, a Water level sensor, and a temperature sensor above the cooling tower.

After the positions of the cooling tower and container are fully determined, it is necessary to wire four motors and two sensors. The Water level sensor and temperature sensor have been required to be installed in the designated positions. The indicating point (depression) of the Water level sensor must face upwards.

One end of the cable container for the cold tower fan, spray pump, Water level sensor, and temperature sensor is already connected to the terminal inside the cold tower control cabinet, and the other end is reserved inside the container. When it is necessary to flip the wire to the side of the cooling tower, the corrugated pipe metal joint, 10 meters weather resistant metal corrugated pipe, and 5 stainless steel straps in the equipment should be first identified.

All cable wiring locations are at the junction box on the side wall of the cooling tower. The order of the three cooling fans and spray cooling pumps is not specified. The wiring sequence is U, V, W (from left to right). The location of the cooling fan and junction box See Figure 7-22. The Water level sensor is installed as shown in Figure 7-22 Location of the fans and wiring box

below. The wiring diagram is shown in Figure 7-23 Location of the Water level switch and temperature sensor

The wiring steps are as follows:

1: Disassemble the screw sleeve of the metal joint and divide it into two parts: the screw sleeve and the metal joint.

2: The end of the metal joint should be connected to a 10 meters weather resistant metal corrugated pipe and form a whole.

3: Inside the container, pass 6 cables through the screw sleeve and then through the reserved outlet hole (located at the bottom right of the inlet and outlet Water pipe intersection).

4: Thread these 6 cables through one side of the metal joint and the other side of the corrugated pipe.

5: Insert the metal joint into the reserved outlet hole of the container, where the outer part of the container is a metal joint and the inner part is a screw sleeve. Tighten the screw sleeve to the metal joint end and tighten it to a fixed torque to achieve good sealing effect.

6: When laying out metal corrugated pipes outdoors, they should follow the lower one of the interconnecting pipelines between the container and the cooling tower, and be fixed with 5 stainless steel straps included in the accessories.

7: The other end of the cable should be connected to the junction box left by the cooling tower. The correct wiring sequence should correspond one by one between the number tube of the cable and the number of the terminals in the junction box.

8: After the wiring is completed, it is necessary to start and debug the operation to ensure its correctness and good wiring.

 **Danger**

In addition to the location of the junction box, it is also necessary to confirm whether the wiring of the fan itself is well connected. You need to climb the ladder from the cooling tower to the top to confirm. Do not turn on the power before confirming.

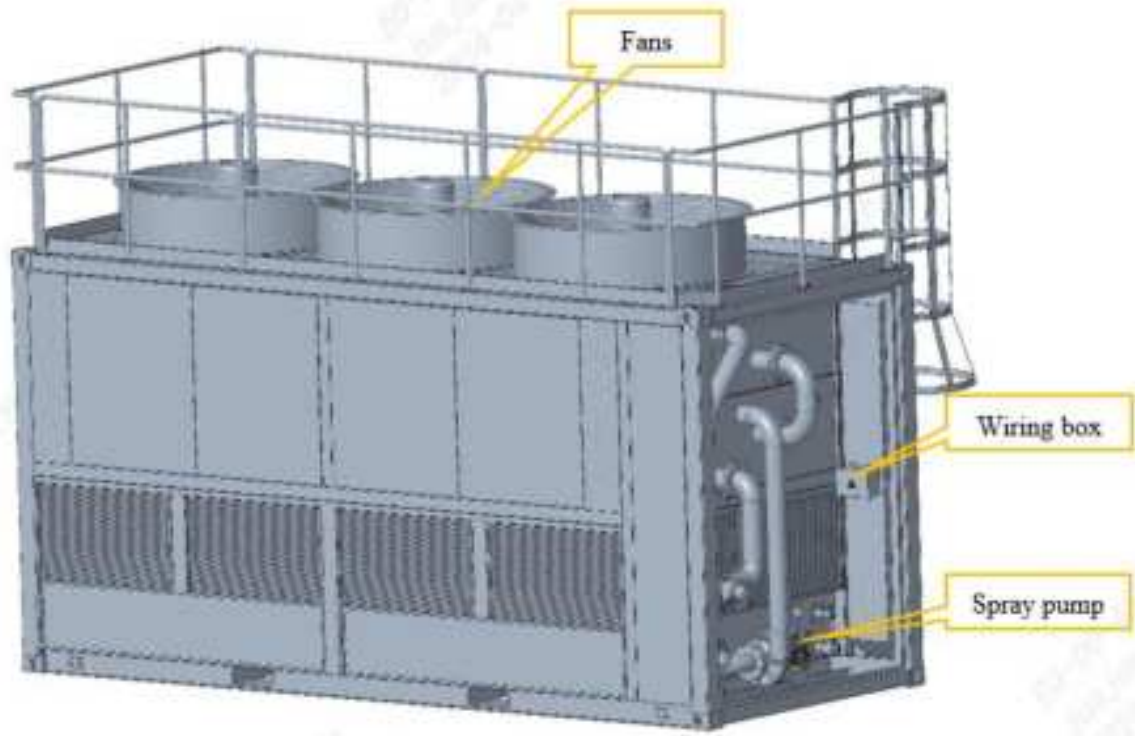

Figure 7-22 Location of the fans and wiring box

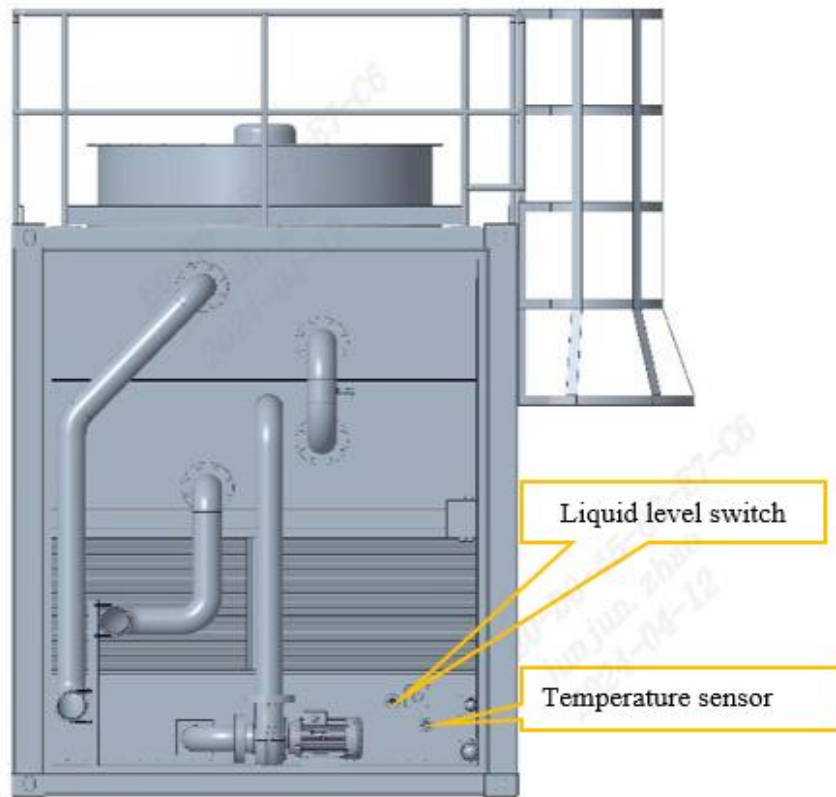

Figure 7-23 Location of the Water level switch and temperature sensor

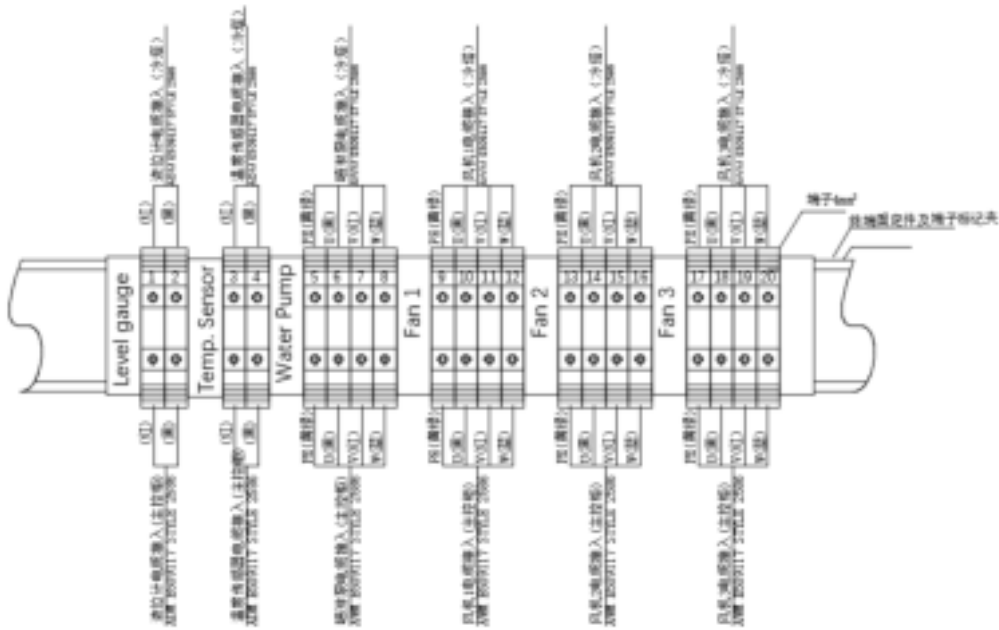

Figure 7-24 Wiring diagram of the cooling tower

7.5 System Power-on and Power-off

The switch in the main control cabinet are shown in the following figure:

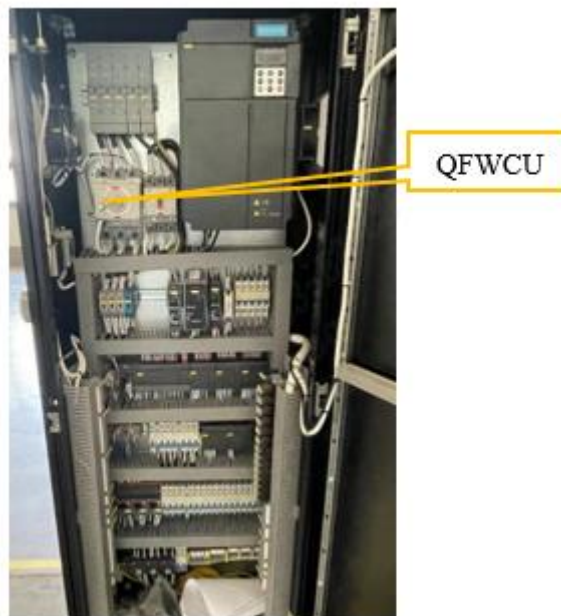

Figure 7-25 Internal view of the main control cabinet

1) Functional Description of Circuit Breakers

Table 7-1 Functional description of circuit breakers in the main control cabinet

SN	Name	Starting point	Direction	End point
1	QFWCU	Power incoming XT1 L1,L2,L3	→	XD11, XD12, XD13, L1, L2, L3
2	QFKR1	XD11 L1	→	Power monitor L1
3	QFKR2	XD12 L2	→	Power monitor L2
4	QFKR3	XD13 L3	→	Power monitor L3
5	QFHL1	XT1 L1	→	Power indicator light (white)
6	QFHL2	XD11 L1	→	Closing indicator light (green)
7	QFD1	L1,N	→	Backup power supply
8	QFaSW	XD11 L1	→	Distribution cabinet switch power supply
9	QFbSW	XD11 L1	→	Distribution cabinet switch power supply
10	QFVF01	XD11,XD12,XD13 L1,L2,L3	→	Main pump frequency converter R, S, T
11	-QFVF02	XD11,XD12,XD13 L1,L2,L3	→	Cold tower fan frequency converter R, S, T
12	-QFG01	Cold tower fan frequency converter U, V, W	→	Cooling tower fan front thermal relay - FRG01 1,3,5
13	-QFG02	Cold tower fan frequency converter U, V, W	→	Cooling tower fan front thermal relay - FRG02 1,3,5
14	-QFG03	Cold tower fan frequency converter U, V, W	→	Cooling tower fan front thermal relay - FRG03 1,3,5
15	-QFVF03	XD11,XD12,XD13 L1,L2,L3	→	Cold tower spray pump frequency converter R, S, T
16	QFCTMF	EV_L1+	→	Power supply 24V+
17	QFV1	EV_L+	→	KAKV102, KAGV102
18	QFV08	EV_L+	→	V008 power supply+
19	QFP1	XD13 L3	→	PLC power supply P1, pin 2
20	QFPZ1	PLC power supply P1, pin 5	→	P1_L+
21	QFP2	L1.4	→	P2 SDR-480-24 pin L
22	QFPZ2	P2 SDR-480-24 pin V+	→	Container lighting RCT4D
23	QFRDC	P2 SDR-480-24 pin V+	→	Distribution cabinet fan
24	QFMF	P2 SDR-480-24 pin V+	→	Cabinet radiator
25	QFP3	L1.4	→	SDR-75-12V P3 pin L
26	QFPZ3	SDR-75-12V P3 pin V+	→	Face recognition power supply,

SN	Name	Starting point	Direction	End point
				door magnetic switch power supply
27	QFP4	L1.4	→	MDR-20-5 P4 pin L
28	QFPZ4	MDR-20-5 P4 pin V+	→	Main control module NanoPi-R4S
29	QFRST	EV_L+	→	Main distribution cabinet A shunt release RCT4D

Table 7-2 Function description of circuit breakers in distribution cabinet A

SN	Name	Starting point	Direction	End point
1	MCB-A1	L1,L2,L3	→	Main busbar L1,L2,L3
2	MCB24-1	L1	→	Power indicator light HL1 X1
3	MCB24-2	Power indicator light HL1 X2	→	L3
4	MCB25-1	L4	→	Closing indicator light HL2 X1
5	MCB25-2	Closing indicator light HL2 X2	→	L6
6	MCB-B1	L1,L2,L3	→	SPD1
7	MCB21-1	L1	→	1#PMM V1
8	MCB21-2	L2	→	1#PMM V2
9	MCB21-3	L3	→	1#PMM V3
10	MCB26	XRDC		Cooling fan L+ in the cabinet
11	MCB15-1, 2, 3, 4, 5			Switch circuit breaker
12	MCB1-1, 7-15			High computing power server circuit breaker

Table 7-3 Function description of circuit breakers in distribution cabinet B

SN	Name	Starting point	Direction	End point
1	MCB-A2	L1,L2,L3	→	Main busbar L1,L2,L3
2	MCB27-1	L1	→	Power indicator light HL3 X1
3	MCB27-2	Power indicator light HL3 X2	→	L3
4	MCB28-1	L4	→	Closing indicator light HL4 X1
5	MCB28-2	Closing indicator light HL4 X2	→	L6

6	MCB-B2	L1,L2,L3	→	SPD2
7	MCB22-1	L1	→	2#PMM V1
8	MCB22-2	L2	→	2#PMM V1
9	MCB22-3	L3	→	2#PMM V1
10	MCB29	XRDC		Cooling fan L+ in the cabinet
11	MCB16-1, 2, 3, 4, 5			Switch circuit breaker
12	MCB8-1, 14-15			High computing power server circuit breaker

2) Precautions for First Power of the System

After the entire system wiring is completed, the equipment can be powered on for debugging. However, before powering on, it is necessary to use a multimeter to measure whether there is a short circuit between phase wires, between phases wire and neutral wire, between phase wire and ground wire, and between neutral wire and ground wire of the two power supplies. If not, it means it can be powered on normally. If any of the above short circuits exist, the fault should be identified first and then powered on. After the front-end of the system is powered on (the system itself is not yet powered on, and the main switch of the distribution cabinet and main control cabinet are not closed), it is necessary to measure the voltage of the front-end to see if it meets the power requirements of the equipment.

The power requirement for this device is AC 400V \pm 5%, 50/60Hz.

Danger

After the system wiring is completed, a multimeter needs to be used to measure the direct connection between the phase wires between the input A/B power distribution cabinets, between the phase wires and the neutral wire, between the phase wires and the ground wire, and between the neutral wire and the ground wire. Is there a short circuit phenomenon? If there is a display showing that the resistance is 0, the short circuit must be checked before powering on, otherwise the system may be at risk of short circuit failure and electric shock.

3) System Power-on Sequence

After the front-end of the system is powered on and the voltage meets the requirements of the device, the system can be powered on at this time.

1: Firstly, power on the main control cabinet.

When the main control cabinet door is opened, first open QFWCU, and then open all circuit breakers inside the main control cabinet. QFP1 and QFPZ1 are switches for 24V power supply in

PLC, QFP2 and QFPZ2 are switches for system 24V power supply, QFP3 and QFPZ3 are switches for 12V power supply, and QFP4 and QFPZ4 are switches for 5V power supply. After powering on, the screen and PLC on the cabinet door begin to work.

When the main control cabinet door is closed and the system needs to be powered on, first open all miniature circuit breakers and one molded case circuit breaker QFVF02 inside the cabinet, then close the cabinet door and open QFWCU through the cabinet door operating handle. At this point, the equipment has been powered on.

Trained electricians can operate the system through a touch screen, set parameters, modify thresholds, change operating modes (automatic/manual), start and stop a certain motor separately, or operate automatically. At this point, the Water cooling system can be run first, and the supply temperature can be controlled within the required temperature range before meeting the conditions for starting the high computing power server.

2: After the main control cabinet is powered on, according to the operation process of the control system, it is only when the Water supply temperature is maintained near the target temperature that the high computing power server can be turned on. At this point, the circuit breakers in distribution cabinets A and B can be opened to start powering on the high computing power server.

The power on sequence of the distribution cabinet is as follows:

First open MCB-A1 and A2, then other circuit breakers, and then start rows of high computing servers in an orderly manner as required. Due to a total of 210 high computing power servers, there are a total of 14 rows. When starting a high computing power server, the next row should be started at an interval of 20 seconds after starting one row (15 high computing power servers), and so on.

Caution

Please refer to Table 8-1 for the corresponding device and switch position numbers.

4) System Power-off Sequence

When the system needs to power off for some reason, as required, first disconnect the power supply of the high computing power server to ensure that the water temperature before and after the power outage is consistent, which is equivalent to protecting the power module of the high computing power server. After the power outage of the high computing power server, the Water cooling system is manually stopped through the touch screen. At this time, the water temperature will slightly rise, but it has no impact on the system. Finally, disconnect the main power supply of

the main control cabinet and distribution cabinet, leaving the entire system in a completely powered off state.

The above practice is a safe power outage behavior. However, when a serious fault occurs in the system, the emergency stop button on the inner door of the container can be directly pressed, causing the main circuit breaker of the distribution cabinet and the main circuit breaker of the main control cabinet to trip instantly, leaving the system in a completely powered off state, facilitating professional maintenance work.

 **Danger**

In an emergency, please press the emergency stop button on the front of the power distribution cabinet. The emergency stop button on each power distribution cabinet controls the power supply of the power distribution cabinet. When pressed, the power distribution cabinet is powered off, but the switch, lightning protector, and electric meter display will be powered on. There will be no power outage, and professionals must be responsible for opening the door panel.

 **Caution**

Press the emergency stop, and before re-powering after troubleshooting, you need to rotate the emergency stop switch clockwise to release, the main switch of the distribution cabinet, and the main control cabinet switch first move to the OFF position and then re-close.

5) Personnel Responsibility Division

Responsibilities of general operation and maintenance personnel:

General power on/off work (disconnecting or merging circuit breakers), system start up and shutdown (touch screen button operation), network cable detection and replacement.

Professional electrician responsibilities:

General power on and off work (disconnecting or merging circuit breakers), system start up and shutdown (touch screen button operation), network cable detection and replacement. When the equipment experiences short circuits, phase loss, reverse phase, sensor no display, corresponding equipment no response after circuit breaker closing, and abnormal motor operation, professional electricians are required to operate.

7.6 Touch Screen Operation

 **Danger**

Note: It is strictly prohibited to plug or unplug the communication cable between the touch screen and PLC while the power is on, otherwise the touch screen or PLC communication serial port will be damaged!

! Caution
 The touch screen operation password is "1000".

1) Mode Switching Interface

After the system is powered on, the screen displays as , and this mode defaults to cold tower mode.

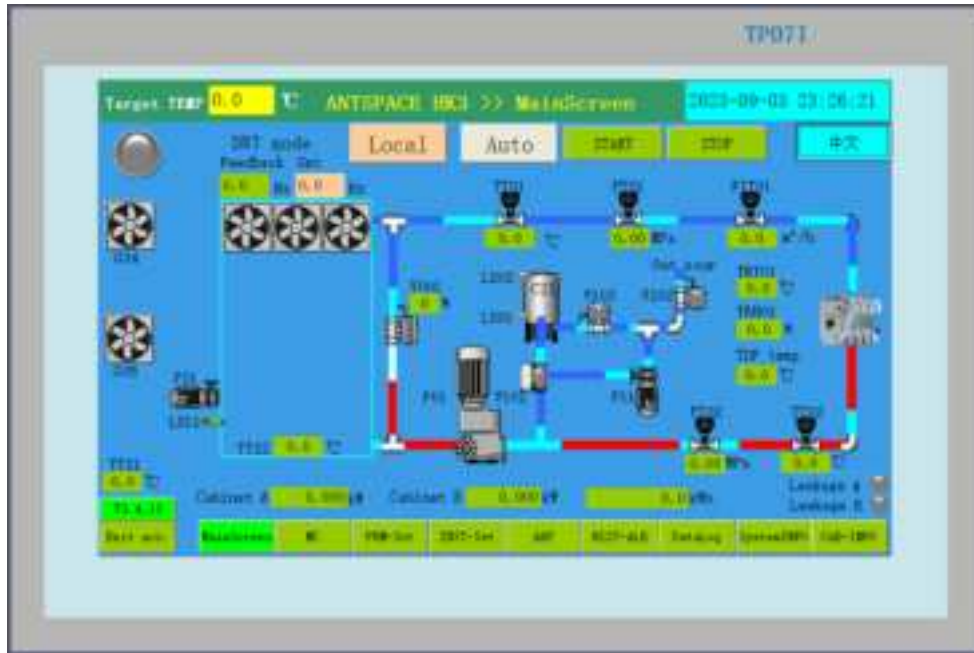

Figure 7-26 Screen display interface

The screen display device has control modes of "Auto/Manual", "Local/Remote", target temperature (settable), total fault display, and analogue quantity display. The system can set the operation control mode of the device through the main screen.

When the water cooling system is adapted to board to board components, it is necessary to first switch to board to board mode.

The switching method is to click on the version number at the bottom left of the cold tower mode interface, such as V3.4.11, and the interface will jump to the mode selection interface, as shown below Figure 7-27.

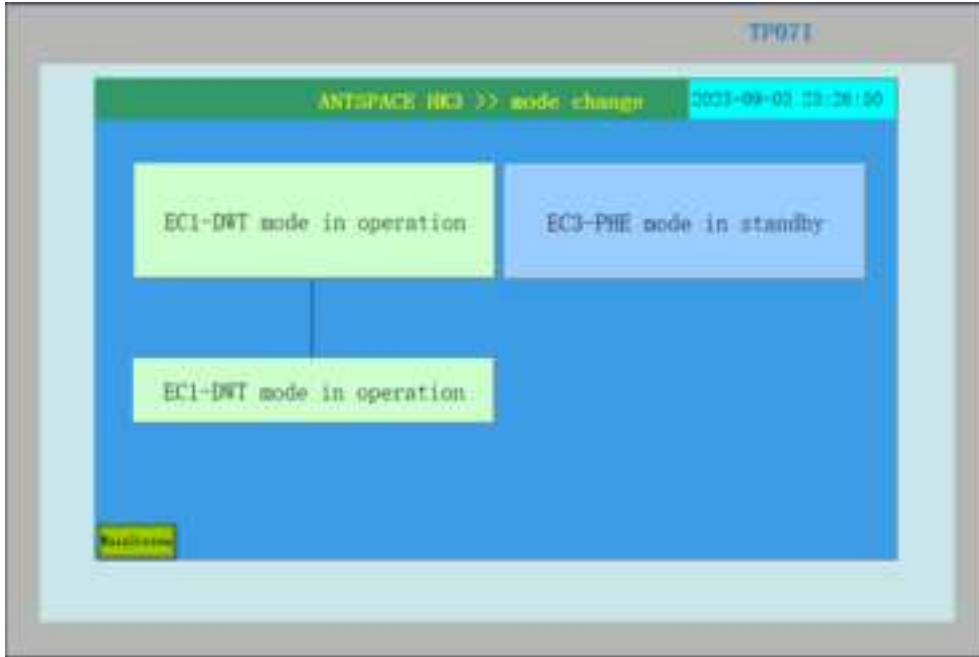

Figure 7-27 Mode selection interface (EC3-PHE mode in standby)

Click the " EC3-PHE mode in standby" button, and the interface button will jump to " EC3-PHE mode in operation ", as shown in Figure 7-27. Click the "Main Screen" button at the lower left corner of the interface to enter the Home interface of board change mode, as shown in Figure 7-28.

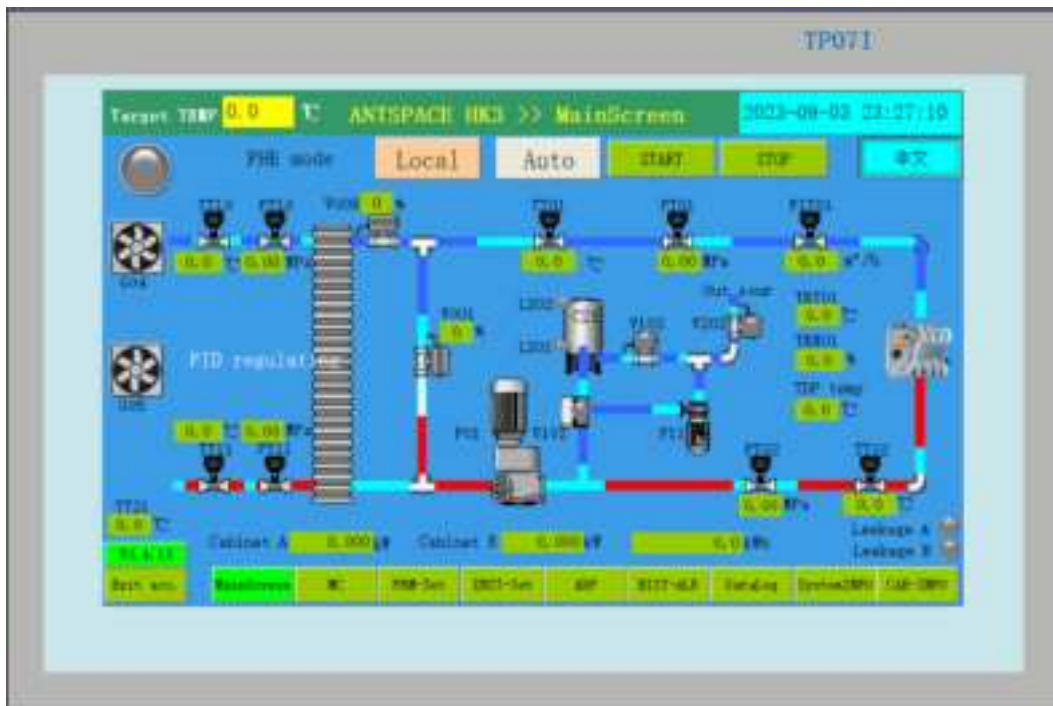

Figure 7-28 Home interface of EC3-PHE mode

2) Main Screen Interface

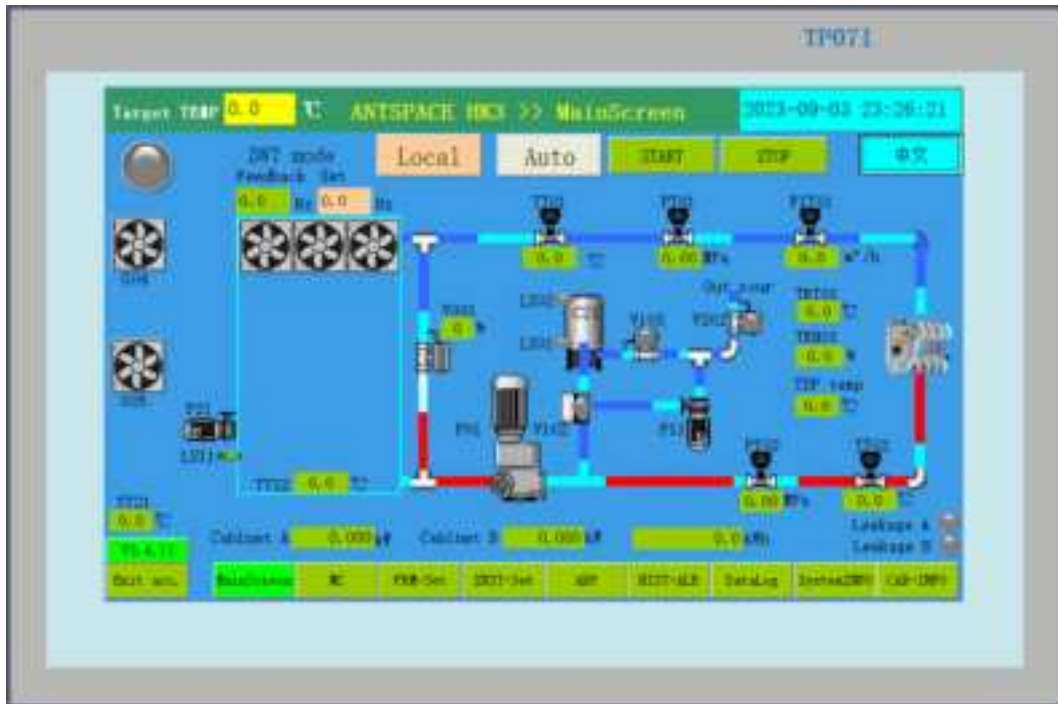

Figure 7-29 Main Screen Interface

When in the cold tower mode, manual control is used for debugging and automatic control is used for system operation.

Click the "MC" button to enter the manual control interface.

Click the "PRM-Set" button to enter the parameter setting interface.

Click the "INST-Sets" button to enter the instrument settings interface.

Click the "ADP" button to enter the fault alarm interface.

Click the "HIST-ALR" button to enter the historical alarm interface.

Click the "Data Log" button to enter the data information interface.

Click the "System INFO" button to enter the system information interface.

Click the "CAB-INFO" button to enter the power and positioning information interface.

The remote control mode can only be effective when the unit is in automatic mode, and the priority is lower than local control.

When the system needs to run automatically, it is necessary to ensure that the internal pressure (PT01/PT02) of the system is higher than 0.05 MPa, and then set all parameters in the parameter setting interface. Then click on "START" on the main screen, and the motors in the system will

execute in the order of automatic control logic. When you need to close, click on 'STOP' on the Home interface.

3) Manual Control Interface

When the device needs to be debugged with Water, it is necessary to adjust the device control mode to the "MC" position, and then enter the "manual control" screen, as shown in the following figure:



Figure 7-30 Manual control interface

At this point, the motor and frequency converter to be operated can be started by jogging. In general, when the system needs to add Water, it is necessary to manually start and corresponding electric valves, make-up pumps, and circulation pumps. However, before starting, it is necessary to ensure that the motor runs in the correct direction.

Therefore, after powering on, turn on the 1 # exhaust fan and observe its running direction. When the wind blows out of the container, it indicates positive rotation. Before the equipment leaves the factory, all motors have been debugged and turned forward. Therefore, it is only necessary to observe the operating status of one motor. When the motor reverses, it is necessary to adjust the phase of the three-phase power input of QFWCU, that is, change the phase sequence of the two cables.

4) Parameter Setting Interface

The parameters in the system have been set, and the screen is as follows (which will be displayed in the real screen):



Figure 7-31 Parameter setting interface

After the unit is turned on, the above parameter values have been set to the initial default values. For the first start up, it is necessary to check whether the parameter setting interface is consistent with Figure 7-31. If there are any differences, they need to be reset according to the figure. The parameter setting interface allows manual settings of automatic Water replenishment parameters, V001 electric butterfly valve opening, container fan operating parameters, cold tower fan operating parameters, and spray pump operating parameters. In addition, through the buttons in the manual Water replenishment box in the parameter setting interface, manual Water replenishment can be performed for different operating conditions of the system.

5) Instrument Setting Interface



Figure 7-32 Instrument setting interface

The alarm thresholds for supply and return Water temperature, supply and return Water pressure, flow rate, temperature inside the main control cabinet, temperature inside the distribution cabinet, and cold side pressure difference can be set through the instrument setting interface. The values shown in Figure 7-32 are the default initial alarm values. For the first start up, it is necessary to check whether the parameter setting interface is consistent with Figure 7-32. If there are any differences, they need to be reset according to the figure. If modifications are needed, please ask the operation and maintenance personnel to determine the possible problems before making the modifications, and confirm that they do not affect the system operation before making certain modifications to the parameters.

6) Alarm Display Interface

After the system is running, if there is a fault in the system, it will be displayed on this screen.

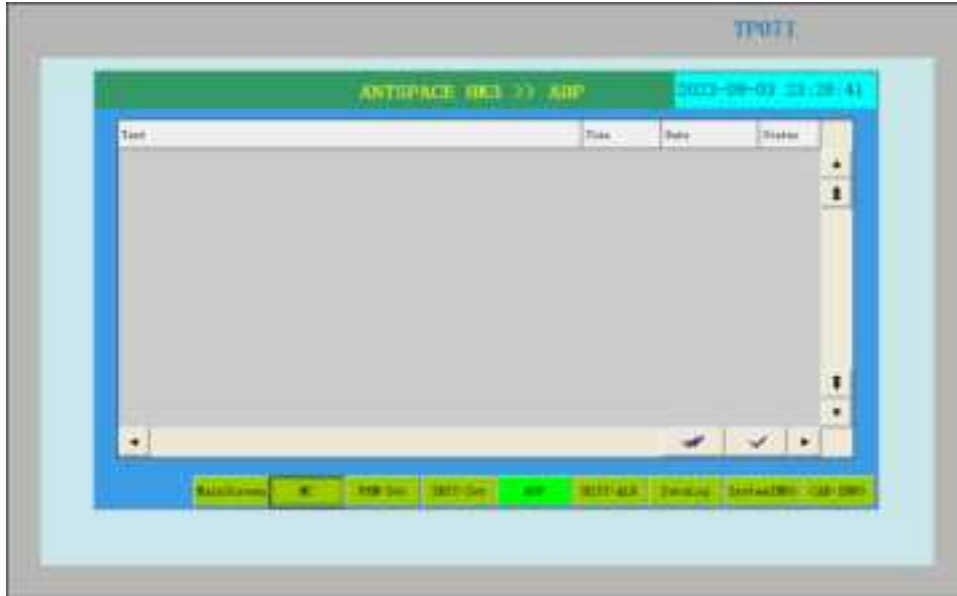

Figure 7-33 Alarm display interface

After the fault occurs, the yellow alarm light will light up. The fault form will be displayed on the alarm display screen interface. At this point, first analyze the cause of the fault, then troubleshoot it, and finally click on "Reset" in the manual control interface.

7) Historical Alarm Interface

The alarm information in the system will be saved on this screen through time records, making it convenient for users to find the fault time.



Figure 7-34 Historical Alarm Interface (Example, non real situation)

8) Data Log Interface

This screen can display information such as supply temperature, return temperature, supply pressure, return pressure, and supply flow rate. Each parameter corresponds to a different colour.

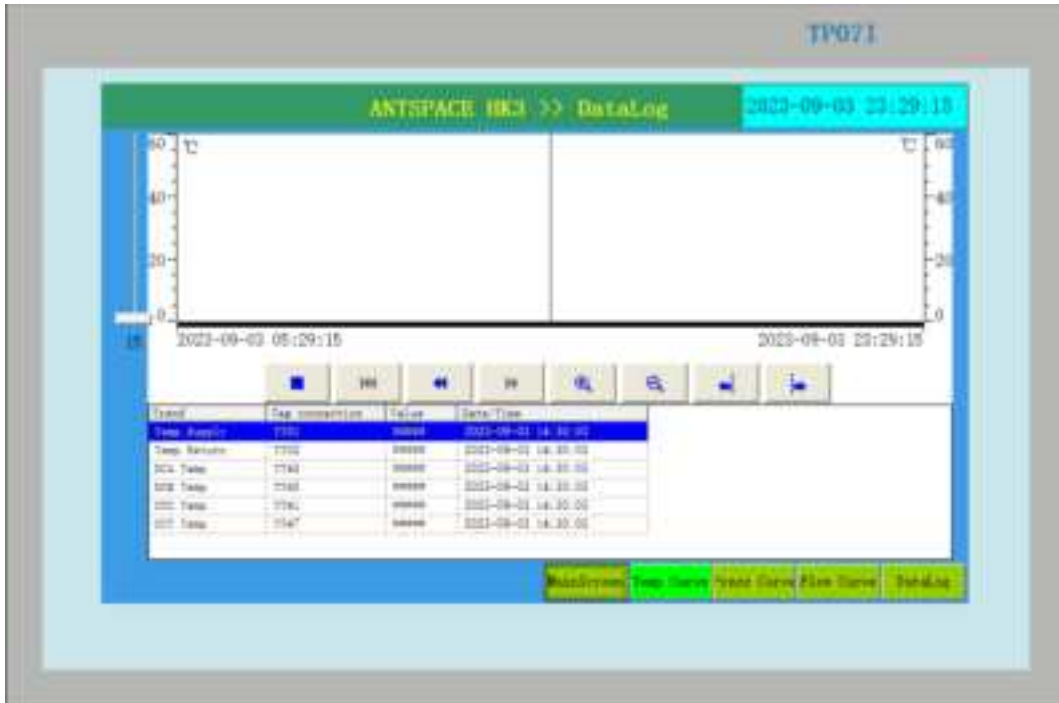

Figure 7-35 Temperature curve interface

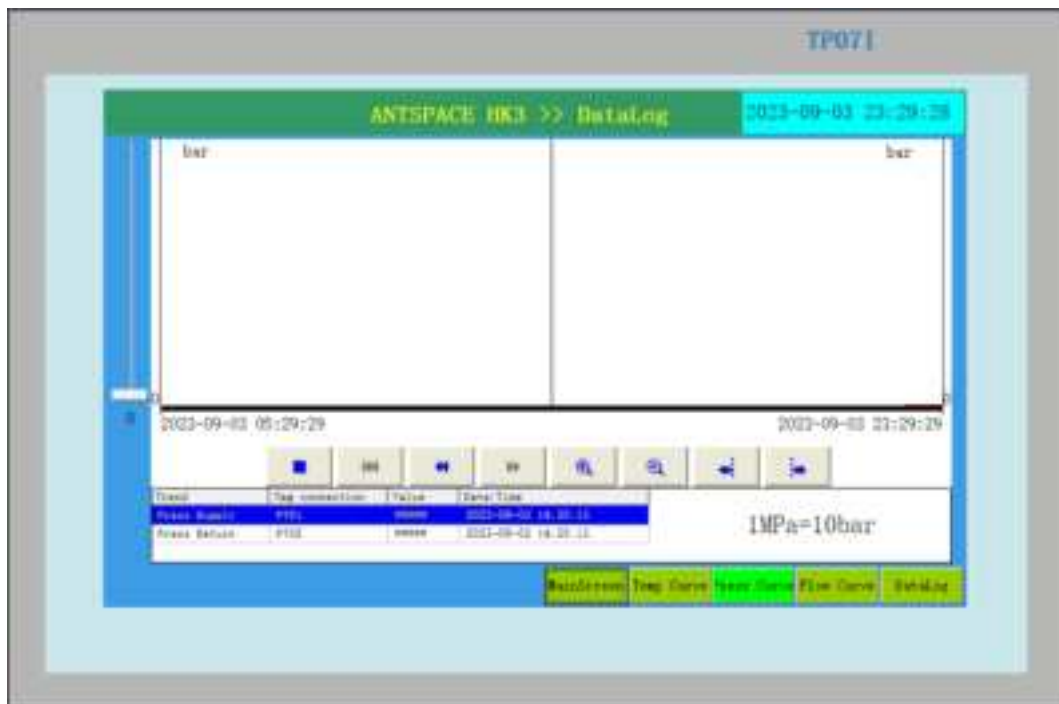

Figure 7-36 Pressure curve interface

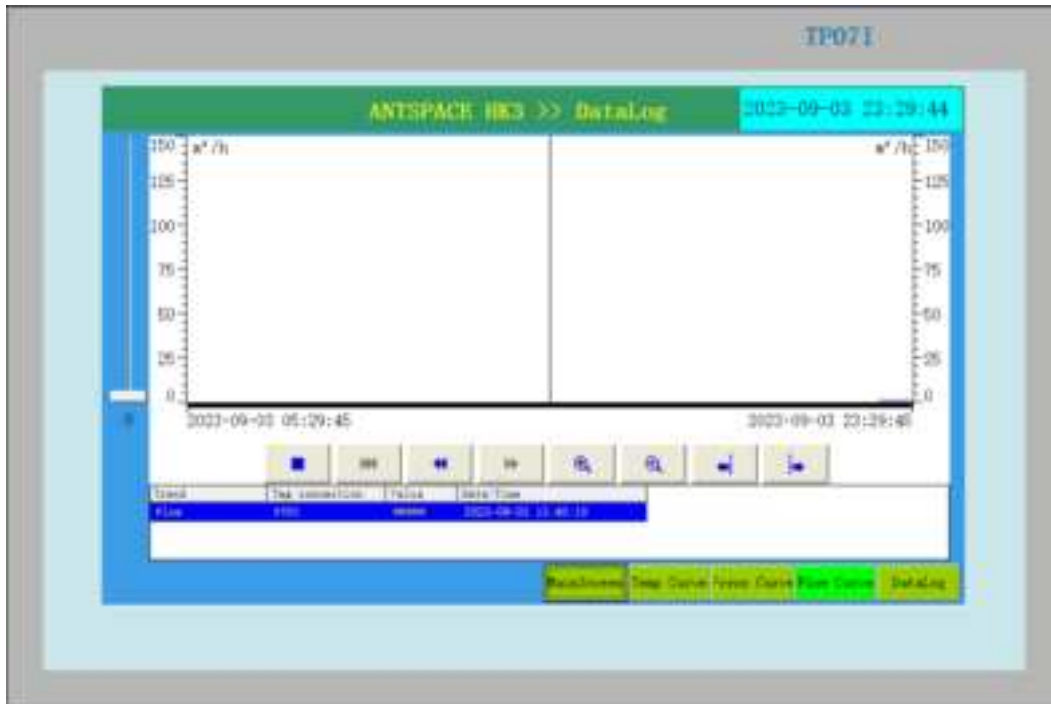

Figure 7-37 Flow curve interface

9) System Information Interface



Figure 7-38 System Information Interface

The system information interface can set the system clock.

10) Cabinet Information Interface

The screen can display the ambient temperature in three cabinets, the power quality information used in two distribution cabinets, and the longitude and latitude information of the equipment. Among them, power information and latitude and longitude information are used for debugging and display, and the reading format is floating point.

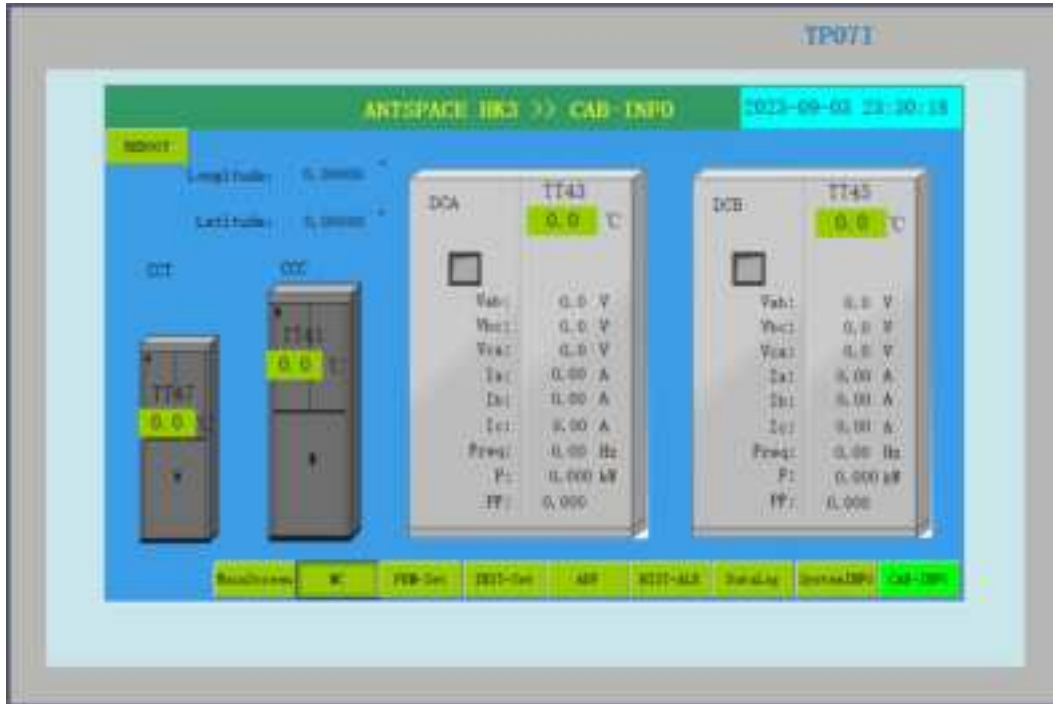

Figure 7-39 Cabinet Information Interface

7.7 ANTSPACE HK3 V6 Container Water Cooling System On-site Installation Summary

11) On-site Installation Summary

After the equipment is transported to the site, it needs to be installed in the order shown in Table 8 4. After installation is completed, the control mode can be changed to automatic. Click One Click Start and the system will automatically run.

Table 7-4 On-site installation summary

SN	Installation steps	Remarks
1	Location and lifting of containers and cooling towers on site	Taking the water inlet and outlet of the container as the reference, the dry cooling tower is installed on the left side of the container (the inlet and outlet of the dry cooling tower is on the same side as the inlet and outlet of the container), and the distance between the container and the dry cooling tower is required to be 2m, and there shall be no blockage on the top of the dry cooling tower. And take the projection line of the bottom frame of the receiver surface of the container as the benchmark, the projection line of the bottom frame of the receiver surface of the dry cooling tower should be kept in the same straight line with it.
2	Installation of container exhaust fans	
3	Installation of connecting pipeline between container and cooling tower	The pipeline is installed correctly, sealed well, no leakage
4	Water-cooled container power distribution	Reasonable alignment, standardized wiring, torque calibration, power-up inspection
5	Water-cooled container pressurization operation	After gas detection for 7 bar/12 h, Water detection for 7 bar/30 min
6	Water filling operation for water-cooled containers	Preparation - system Water replenishment - water tank Water replenishment - regular replenishment of water tank

12) On-site Installation Inspection

The following items need to be verified after installation. Can only start power on after completely qualified.

Table 7-5 Checklist after installation

Item	Content	Confirmation
Container	Proper installation, no tilt. Stand on a horizontal hard floor, leave room for maintenance. All the debris inside removed (cable ties, thrums, etc.).	<input type="checkbox"/> Confirmed
Fan	Correct installation according to component functions.	<input type="checkbox"/> Confirmed

Item	Content	Confirmation
Plugging part	Plugging parts and fixings in and outside the container removed. No debris inside.	<input type="checkbox"/> Confirmed
Rain cover	Proper installation above the inlet.	<input type="checkbox"/> Confirmed
Internal pipeline connection	Reliably fix the clamp and pipe of the replenishment port. Fixation of circulating system pipeline. No loosen. The pressure drop of the pipeline meets the requirements.	<input type="checkbox"/> Confirmed
Cable connection	Correct connection of dry tower cables. Connect unit cables to the PDC through inlet under the rain cover.	<input type="checkbox"/> Confirmed
Inlet and outlet pipes	Correct connection of the pipeline between container and dry tower.	<input type="checkbox"/> Confirmed
Electrical inspection	Supply voltage is within the rated voltage range on the nameplate. No damage on the cable. No open circuit, short circuit or wrong connection in system electrical circuit. Ensure correct connection of all cables in the upper and lower electric control boxes. Ensure the external main power circuit breaker is rated correctly according to current value. Fasten all cable and connectors. No loosen with fasten bolts.	<input type="checkbox"/> Confirmed

8 ANTSPACE HK3 V6 Container Water Cooling System Conventional Faults and Troubleshooting

Table 8-1 List of common faults and troubleshooting methods

Type	Causes	Solution	Remarks
Power failure	1: Phase failure	Check for phase loss in the main power supply	The reason for this situation is that the equipment did not adjust the overvoltage and under voltage values of the power monitor before leaving the factory, or the set values did not match the actual values on site.
	2: Overvoltage	Turn off the upper level circuit breaker QFWCU (in the main control cabinet) to ensure that the main control cabinet is not electrified. Use a flat screwdriver to increase the overvoltage value	
	3: Under voltage	Turn off the upper level circuit breaker QFWCU (in the main control cabinet) to ensure that the main control cabinet is not electrified, and use a flat screwdriver to reduce the under voltage value	
	4: Phase error	Adjust the phase sequence of the power lines connecting the distribution cabinet to the main control cabinet	
Low Water level alarm	The Water level in the water tank inside the container is low	Replenish the water tank inside the container	
Circulation pump failure	Water pump idling, under pressure (low return pressure), etc. cause circulation pump overflow	1: Turn off the circuit breaker (QFWCU) in the main control cabinet first. 2: Reset the motor protector (corresponding to FR1) in the main control cabinet (manually press RESET in the motor protector). 3: Check whether the system operating parameters are normal (pressure and flow will report faults first), and troubleshoot problems according to alarm faults. 4: After troubleshooting, reference Figure 7-30 press the right reset button. 5: Start the circulation pump after an interval of 2-3 minutes.	Warning: after the system is powered on, the circulation pump is prohibited from running idle when there is no Water in the system.

Type	Causes	Solution	Remarks
1#/2# exhaust fan failure	The current of the exhaust fan is too high, and there may be strips in the fan blades that hinder the operation of the fan	1: Turn off the circuit breaker (QFWCU) in the main control cabinet first. 2: If there are debris in the fan blades, first clean them up; If there are no debris and there is no reason for fan failure, the manufacturer needs to be contacted. 3: Reset the motor protector in the main control cabinet (1# exhaust fan corresponds to QFG04; 2# exhaust fan corresponds to QGF05) (manually turn the knob of the motor protector to the vertical position, that is, switch on). 4: After troubleshooting, reference Figure 7-30 press the right reset button. 5: Start the exhaust fan after an interval of 2-3 minutes.	
Water replenishment pump failure	Overload caused by dirty and blocked Y-type filter replacement	1: Turn off the circuit breaker (QFWCU) in the main control cabinet first. 2: Reset the motor protector (corresponding number QFG11) in the main control cabinet (manually turn the knob of the motor protector to the vertical position, which is the closing.) 3: Clean the Y-shaped filter. 4: After troubleshooting, reference Figure 7-30 press the right reset button. 5: After an interval of 2-3 minutes, start the replenishment pump again	Warning: after the system is powered on, the replenishment pump cannot idle when there is no Water in the system.
	The position of the suction port of the replenishment pump is too low, resulting in overload	1: Turn off the circuit breaker (QFWCU) in the main control cabinet first. 2: Reset the motor protector (corresponding number QFG11) in the main control cabinet (manually turn the knob of the motor protector to the vertical position, which is the closing). 3: Lower the external water suction port below the cooling Water tank. 4: After troubleshooting, reference Figure 7-30 press the right reset button. 5: After an interval of 2-3 minutes, start the replenishment pump again.	

Type	Causes	Solution	Remarks
Spray pump failure	Dirty and clogged filter at the water tank suction port causing overload	1: Turn off the circuit breaker (QFWCU) in the main control cabinet first. 2: Reset VF03 in the cooling tower control cabinet (manually turn the knob of the motor protector to the vertical position, that is, switch on). 3: Check if the filter in the cooling tower water tank is dirty or blocked, and clean it after it is dirty or blocked 4: After troubleshooting, reference Figure 7-30 press the right reset button. 5: Start the spray pump after an interval of 2-3 minutes.	Warning: after the system is powered on, the spray pump cannot idle when there is no Water in the system
1# cooling fan failure	The current of the exhaust fan is too high, and there may be strips in the fan blades that hinder the operation of the fan	1: Turn off the circuit breaker (QFVF02) in the main control cabinet first. 2: If there are debris in the fan blades, first clean them up; If there are no debris and there is no reason for fan failure, the manufacturer needs to be contacted.	
2# cooling fan failure		3: Reset the motor protector in the main control cabinet (1# fan corresponds to QFG01; 2# fan corresponds to QFG02; 3# fan corresponds to QFG03) (manually turn the knob of the motor protector to the vertical position, which means that it is closed).	
3# cooling fan failure		4: After troubleshooting, reference Figure 7-30 press the right reset button. 5: After an interval of 2-3 minutes, turn on the cooling fan again.	
Leakage alarm	There is Water leakage from the inlet and outlet of the high computing power server to the floor, wetting the leakage sensor.	1: Find areas on the floor where there is Water. 2: Above this area, carefully search for any leakage from the inlet and outlet of the high computing power server. 3: After finding the leaking area, handle it by replacing the quick plug and corrugated pipe, then clean the leaking site and wipe the leaking monitoring tape dry.	

Type	Causes	Solution	Remarks
Cold tower Water level low alarm	The water level inside the cooling tower decreases	Timely replenish the cooling tower and reset the fault	After a low Water level alarm in the cooling tower occurs, the system starts timing. After about 50 minutes, the spray pump stops spraying. To avoid overheating of the high computing power server due to the spray pump stopping spraying, on-site operation and maintenance personnel are requested to replenish the Water in a timely manner after seeing the alarm.
High Water supply temperature alarm	1: Cooling fan not running	Check whether the fan operates normally and whether the power supply circuit of the fan is normal	
	2: Spray pump not running	Check whether the spray pump operates normally and whether the power supply circuit of the spray pump is normal	
	3: Temperature sensor damaged	Replace the temperature sensor. The alarm value for high Water supply temperature can be set on the screen as needed	
	4: Abnormal water level in the cooling tower	Check the water level of the cooling tower to ensure normal water replenishment	

Type	Causes	Solution	Remarks
High Water supply temperature alarm	After the high Water supply temperature alarm occurred, the operation and maintenance personnel did not handle it in a timely manner, resulting in a continuous increase in the Water supply temperature	Before identifying the cause, it is possible to consider shutting down some high computing power servers, reducing the load, and then finding the cause of the high Water supply temperature alarm. The alarm value for high Water supply temperature can be set on the screen as needed.	
High Water supply pressure alarm	1: Filter clogged	Clean the filter element	
	2: Water supply and return valve malfunction or incomplete opening	Open the Water supply and return valves	
	3: Pressure sensor failure	Replace the pressure sensor	
Low return Water pressure alarm	1: Insufficient cooling Water in the water tank	Replenish the water tank with cooling Water	
	2: Replenishment pump failure	Check the cause of the malfunction of the replenishment pump	
	3: Pressure sensor failure	Replace the pressure sensor	
	4: Leakage	Check for system leaks	
Low Water supply flow alarm	1: Water supply and return valve malfunction or incomplete opening	Open the Water supply and return valve	
	2: Dirty and clogged filter	Clean the filter element	
	3: Flow sensor failure	Replace the flow sensor	
	4: Leakage	Check for system leaks	

Type	Causes	Solution	Remarks
Condensation alarm	High environmental humidity	After the on-site operation and maintenance personnel see the alarm message, they only need to increase the target value of the supply Water temperature by 5°C to prevent condensation.	The logic set in the program is: when the dew point temperature value is greater than the supply Water temperature value - 5°C, the system will prompt a condensation alarm
Pressure display fluctuations	1: There is air in the system	Please ask on-site operation and maintenance personnel to open the exhaust valve for exhaust	
	2: System Water shortage	If the return pressure is lower than the set value, the replenishment pump will automatically replenish the system	
	3: Sensor damage	Replace the sensor	
No pressure display	1: Sensor damage	Replace the sensor	
	2: Loose cables	Check the wiring circuit of the pressure sensor and tighten it	
	3: The PLC acquisition channel is damaged	Replace the module corresponding to the PLC sensor.	
The pump is running, but the flow rate is insufficient	1: There is air at the water pump suction port	Open the exhaust port above the water pump suction port with a wrench, wait until there is even Water flowing out, and repeat 2-3 times (refer to the user manual for specific operations)	
	2: Filter clogged	Clean the filter element	
	3: Insufficient system coolant (low return pressure)	Replenish the system	
Fan not running	1: Motor burnt out	Replace the fan.	
	2: Loose cables	Under live conditions, use a multimeter to check the power supply of the fan and tighten it when power is cut off.	
	3: Circuit breaker tripped	Close the circuit breaker	

Type	Causes	Solution	Remarks
Noise and abnormal noise	1: Water pump cavitation	Check the pressure on the Water inlet side (return pressure or pressure gauge) and replenish the Water in a timely manner	
	2: Pump shaft connection issue	Check the mechanical connection of the pump shaft	
	3: Insufficient lubrication of motor shaft	Adding lubricating oil	
	4: Safety valve action	Check if there is too much Water in the water tank, unable to release pressure in a timely manner, and discharge excess Water from the water tank	
Water pump shaft seal leakage		Replace the water pump shaft seal	

9 ANTSPACE HK3V6 Container Water Cooling System Maintenance

9.1 Overview

Preventive maintenance refers to the maintenance carried out at predetermined intervals or according to prescribed guidelines to reduce the probability of product failure or prevent functional degradation, mainly including adjustments, regular inspections, and necessary repairs. Familiarize equipment maintenance and operators with the performance, structural principles, usage methods, and precautions of the product, so that the equipment can perform its intended functions.

9.2 Preventive Maintenance

1) Operator Monitoring

Operators monitor the status of equipment during normal use, with the aim of identifying potential faults.

Once the operator discovers a system malfunction alarm, they should quickly conduct fault confirmation and inspection to find the cause of the malfunction.

2) Application Check

During normal use of the equipment, operators conduct regular inspections as planned to determine whether the product performs the specified functions.

a) Check if the connections of the Water supply and return pipelines, power lines, etc. are correct.

Inspection requirements: No leakage at all pipelines and connections, and no damage to cables.

Inspection method: visual inspection

b) Check if the return Water pressure (back pressure) is low.

Inspection requirements: the return Water pressure is higher than 0.05MPa (observe the Home interface of the touch screen or the pressure gauge), and if the pressure is lower than this value, Water replenishment is required.

Inspection method: visual inspection and data comparison

c) Check the Water supply system and record temperature, pressure, and other data every half a day.

Inspection requirements: Record the supply/return Water temperature, supply/return Water pressure, and supply Water flow data, and observe whether the data tends to stabilize during long-term operation.

Inspection method: visual inspection and data comparison.

d) Check the fault alarm status of the system, such as temperature, pressure, flow rate, etc. (the above fault status is displayed in the fault alarm interface on the touch screen), and record it every half a day.

Inspection requirements: Check the system alarm points and follow the instructions for troubleshooting.

Inspection method: visual inspection and on-demand testing.

9.3 Regular Inspections

1) Maintenance of Filters

The system is divided into internal circulation and external circulation, with the internal circulation medium being coolant and the external circulation medium being tap water. The system has set up a filter to filter the internal and external circulation, and the filter needs to be cleaned after the system has been running for a period of time.

The filter is divided into three parts, and the corresponding cleaning time requirements are as follows:

- a) Cooling tower spray pump suction filter, cleaning cycle is once a month.
- b) The filter in the internal circulation pipeline of the pump unit Water supply system has a cleaning cycle of once a month (or as needed).
- c) The Y-shaped filter in the internal circulation pipeline of the pump unit replenishment system has a cleaning cycle of once every six months (or as needed).

The cleaning method is to wash with clean water and rinse thoroughly before use.

Operation steps:

- a) Cut off the main power supply of the equipment.
- b) Referring to Figure 9-1, close the maintenance butterfly valves in the system, open the drain ball valve below the pipeline filter component, and drain the local Water in the pipeline.

Caution

The discharged coolant needs to be stored in a clean container, and the coolant discharge must comply with local discharge standards. After the butterfly valves at both ends of the filter are closed, about 10L of coolant will be discharged. A 20L container is required. The discharged coolant cannot be directly added to the water replenishing tank for reuse without treatment.

- c) After finding the position of the filter, open the manual exhaust valve and manual drain valve, remove the clamp connection, and take out the pipeline filter element from the handle.

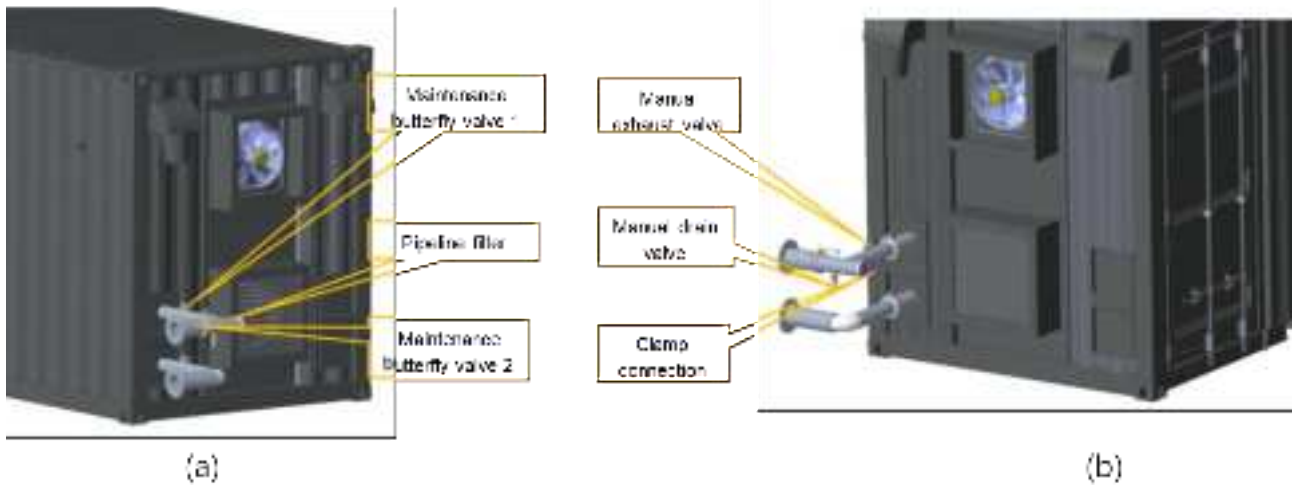

Figure 9-1 Location of butterfly valves and pipeline filters for pipeline maintenance

- d) Remove and clean (or replace) the filter screen inside the filter. Reference .
- e) Install the cleaned filter screen, tighten the clamp with a wrench, and close the valve
- f) After the equipment is powered on again, fill the system replenishment tank with coolant.
- g) .
- h) Install the cleaned filter screen, tighten the clamp with a wrench, and close the valve
- i) After the equipment is powered on again, fill the system replenishment tank with coolant.



Figure 9-2 Remove the pipeline filter

⚠ Caution
 The coolant discharged from the filter cannot be directly added to the rehydration water tank.

2) Pipeline Leakage Maintenance

After six months of equipment operation, the pipeline network should be inspected for leakage prevention for six months. If any leakage or leakage is found, it should be immediately shut down for maintenance.

Maintenance should first stop the operation of the load components on the user end, and then stop the operation of the equipment for repair. After completing the leak detection, pay attention to replenishing the system with coolant.

3) Maintenance of Electrical Components

After six months of equipment operation, it is necessary to inspect and maintain the wiring terminals and crimping screws on the electrical components of the main control cabinet inside the water pump cabinet to prevent looseness of the wiring terminals and crimping screws, which may cause poor contact and damage to the components and prevent normal operation of the equipment, thereby affecting the operation of the entire container Water cooling system.

Caution

Daily operation inspection needs to pay attention to whether there is abnormal noise in system operation, abnormal reading display, and system operation alarm information. If there are any abnormalities, eliminate them promptly.

4) Coolant Drainage

After 1-2 years of operation of the system and water tank, there may be some debris in the system pipeline, and the system coolant should be promptly drained and replaced.

Caution

The system operates with about 1500L of coolant. Please prepare sufficient storage volume in advance for sewage discharge.

Operation Steps:

- a) Find the position of the discharge valve (Figure 9-3).
- b) Connect the drain hose to the drain ball valve and tighten it with a hose clamp; Guide the hose outside the equipment and open valve V202 (Figure 9-3) to drain the system.

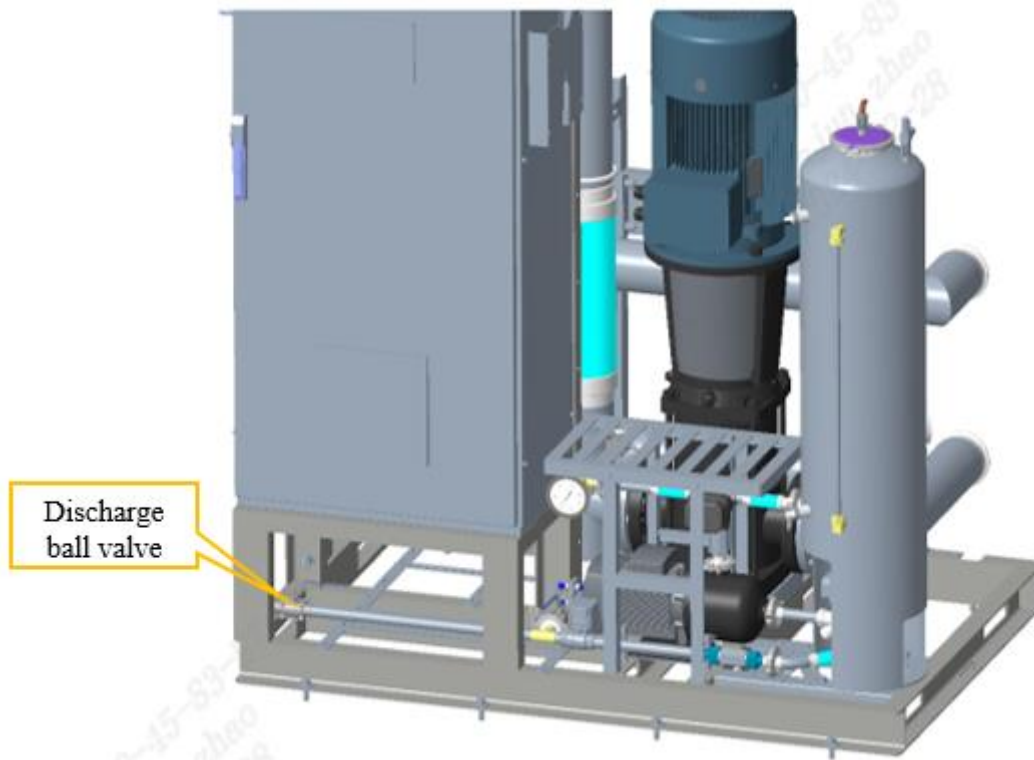

Figure 9-3 Location of discharge ball valve in pump station

5) Water Tank Level Inspection

The system monitors the Water levels in two water tanks (inside the container and in the cooling tower). When the Water level in the water tank falls below the required value, the system touch screen will give an alarm indicating that the water tank level is low. At this time, it is necessary to promptly check for faults and replenish the coolant.

Even if there is no alarm for the water tank level, it should be checked regularly on a daily basis:

The Water level in the water tank inside the container needs to be checked once a week after stable operation. If the water tank does not reach 2/3 of the limit, it needs to be replenished in a timely manner.

The Water level of the cooling tower water tank is required to be checked once a day, and water shutdown is not allowed (unless dry cooling mode is adopted in winter, at which time the internal water of the cooling tower needs to be drained).

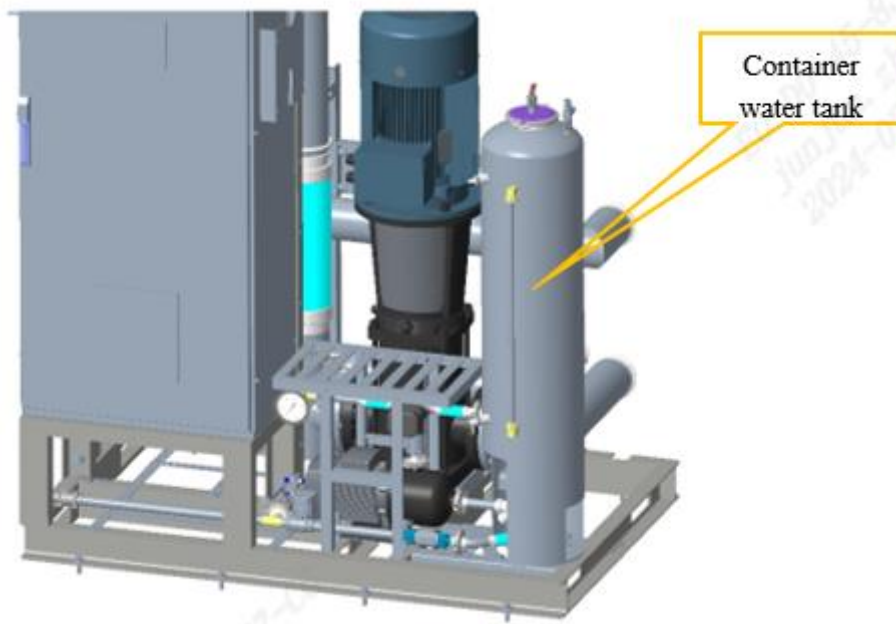

Figure 9-4 Container water tank

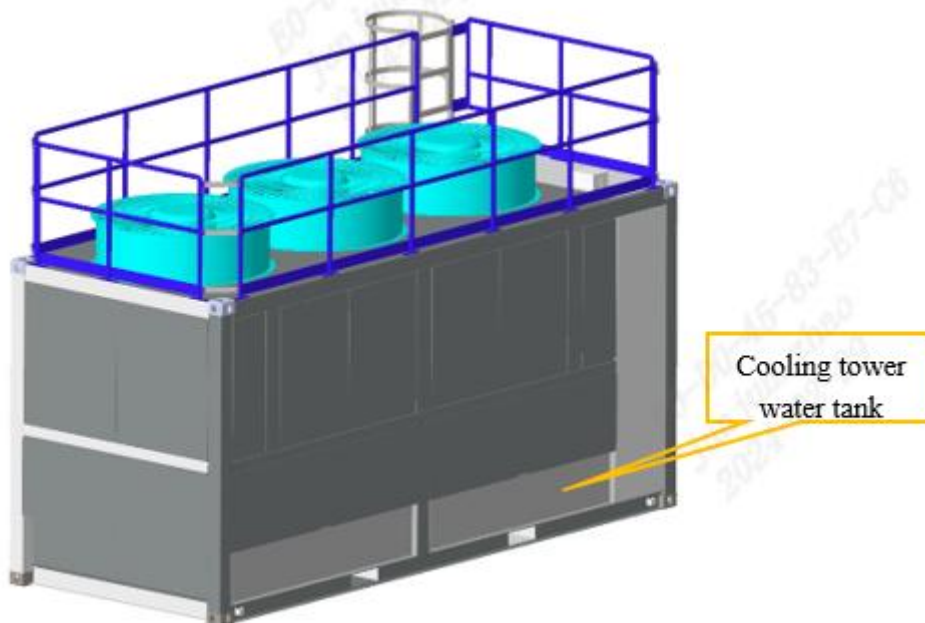

Figure 9-5 Cooling tower water tank

6) Maintenance of Coolant

- a) As the core unit of the container Water cooling system, it is recommended to regularly track and record the coolant, at least once a year (PH value is tested every six months).
- b) When purchasing coolant, it is necessary to focus on the relevant parameters in

- c) Table 9-1. If the requirements are not met, it is necessary to consider refilling and replacing the coolant as appropriate.
- d) Regular testing of coolant focuses on PH value, and it is not recommended to use it when the PH value is below 7 (a PH indicator can be added to the coolant. When the PH is below 6.8, the coolant will change color for easy observation).
- e) The coolant needs to be regularly tested, paying attention to freezing point, ethylene glycol ratio, total hardness, etc. In the later stage, attention should be paid to whether the content of elements such as Al, Fe, Cu increases, as an increase indicates that contact corrosion has already occurred.
- f) It is recommended to regularly add corrosion inhibitors according to the supplier's requirements to maintain the coolant.

**Danger**

The antifreeze must be configured strictly in accordance with the lowest possible temperature in the environment. If the antifreeze is not configured according to the instructions and the ambient temperature is lower than the freezing point of the antifreeze, causing the heat exchanger to freeze and crack, our company will not bear any responsibility!

Table 9-1 Recommended standards for coolant testing

Items	Reference standards		Remarks
Color	Significant color		Visual inspection
Exterior	No odor, sediment, or suspended solids		Visual inspection
Freezing point	<Local minimum freezing temperature		
Boiling point	108°C (low temperature type))		
PH value	7-9		
Reserve alkalinity	≥4ml (organic formula) ≥9ml (including inorganic formula)		
Total hardness	<120 mg/l		
Main element content	B	<20mg/kg	
	Si	<20mg/kg	
	P	<20mg/kg	
	Mo	<20mg/kg	
	Ca	<20mg/kg	
	Al ³⁺	<50mg/L	
	Fe ²⁺	<50mg/L	
	Cu ²⁺	<50mg/L	

Table 9-2 Glycol Refrigerant Concentration vs. Freezing and Boiling Points

Glycol concentration		Freezing point °C
Mass concentration %	Volume concentration %	
0	0.0	0.0
5	4.4	-1.4
10	8.9	-3.2
15	13.6	-5.4
20	18.1	-7.8
25	22.9	-10.7
30	27.7	-14.1
35	32.6	-17.9
40	37.5	-22.3
45	42.5	-27.5
50	47.6	-33.8
55	52.7	-41.1
60	57.8	-48.3

Table 9-3 Recommended standards for deionized water

Index	Deionized water	Reference standards	Remarks
PH value	8.5-9.5	Intel 632983	
Sulfide	<1 ppm	TC9.9/Intel 632983	
Sulfate	<10 ppm	TC9.9/Intel 632983	
Chloride	<5 ppm	TC9.9/Intel 632983	
Bacterial community	<100 CFUs/ml	TC9.9/Intel 632983	
Total hardness (as CaCO ₃)	<20 ppm	TC9.9/Intel 632983	
Conductivity	<20 us/cm (reference value, not mandatory)	TC9.9	High conductivity is not necessarily unacceptable, such as 1000us/cm, as corrosion inhibitors and fungicides will both lead to an increase in water conductivity. It is necessary to understand the reasons behind the sharp increase in conductivity trend during circuit operation. ◦
Residues after evaporation	50 ppm	TC9.9/Intel 632983	
Turbidity	<20 NTU	TC9.9/Intel 632983	
Iron content	0.1 ppm	Industry standards	
Copper content	10 ppm	Industry standards	
Carbon steel corrosion rate	3 mpy (0.075mm/a)	GB/T 50050-2017	
Corrosion rate of copper or stainless steel	0.2 mpy (0.005mm/a)	GB/T 50050-2017	



Caution

Table 9-1 is the media requirements for working conditions where the working environment temperature is lower than 0° C. If the working environment temperature is higher than 0° C for many years, deionized water/purified water can be used as the secondary side internal circulation. Media, the corresponding media requirements are shown in Table 9-3.

Caution

In order to ensure long-term reliable operation, when using deionized water/or purified water as the internal circulation medium, check it once every 1-2 weeks, and replace the internal coolant every 1-2 months.

Danger

When using deionized water as the internal circulation medium, please strictly comply with the usage environment above 0°C. Otherwise, if the temperature is below freezing point, unexpected power outage will cause the internal pipes of the system to freeze and cause the pipes to burst.
 When using deionized water/pure water, the pH value, conductivity and related index parameters of the coolant must be regularly tested and recorded. When the requirements in Table 10-3 are exceeded, or there are abnormal changes, new deionized water/pure water that meets the requirements must be replaced in time. water.

7) Maintenance of Cooling Towers

After the cooling tower is put into operation, it is necessary to regularly check the operation status and pay attention to the following points:

- a) After the cooling tower enters the water, it must be strictly controlled. Damaged water pipes and nozzles should be replaced in a timely manner to avoid affecting the water distribution effect or damaging the water spraying device. If there are any debris, it should be removed in a timely manner.
- b) The suspended solids content of spray water is generally controlled below 20mg/L. When the suspended solids content increases, water quality treatment agents should be appropriately added for treatment. For long-term operation, scale inhibitors should be considered. The water quality requirements are shown in the table below (refer to GB/T18430.1-2007). It is recommended to replace the spray water at least twice a year, and the specific situation should be increased according to the local water quality situation of the project.

Table 9-4 Recommended standards for spray water

Cooling Water Quality					
Items		Reference value		Inclination	
				Corrosion	Scaling
Benchmark items	PH (25°C)	uS/cm	6.5~8.0	O	O
	Conductivity (25°C)		<800	O	O
	CL ⁻	mg(CL ⁻)/L	<200	O	

	SO^{2-}	mg(SO^{2-})/L	<200	O	
	Acid consumption (Ph=4.8)	mg($CaCO_2$)/L	<100		O
	Full hardness	mg($CaCO_2$)/L	<200		O
Reference items	Fe	mg(Fe-)/L	<1.0	O	O
	S^{2-}	mg(S^{2-})/L	Not allowed to be detected	O	
	NH^+	mg(NH^+)/L	<1.0	O	
	SiO_2	mg(SiO_2)/L	<50		O
Note: O represents factors related to corrosion or scaling tendency.					

- c) If abnormal phenomena are found in the fan system, it should be immediately stopped for inspection and troubleshooting. The blades should be repaired or replaced based on the actual erosion and wear situation to ensure that the cooling tower is in good operating condition;
- d) During the use of the cooling tower, if excessive water loss is found, manual replenishment devices should be used in a timely manner to replenish water. In addition, check whether the water collector is damaged and whether the water collection tank is leaking;
- e) It is required to clean the inside and outside of the tower once a year to prevent the accumulation of dirt from affecting the smooth flow of water.;
- f) After the cooling tower is shut down, the residual water in the water collection tank and pipelines must be emptied. If the shutdown time is long, the entire tower should be inspected to ensure safe and normal operation next time;
- g) Flammable materials such as fillers and water collectors are strictly prohibited from coming into contact with open flames during use or maintenance;
- h) Under the freezing point temperature in winter, the system will switch to dry cooling mode. At this time, it is necessary to drain the residual water in the water collection tank and pipelines to prevent equipment damage caused by icing;
- i) The filters inside the water collection tank need to be cleaned once a month to prevent damage to the spray pump caused by dirt and blockage;
- j) PVC fillers should be washed regularly and should not be operated under conditions where the cooling water temperature is higher than 50°C.

Warning

When the system operating water temperature is significantly higher than the set value, please check whether the cooling tower coil is seriously scaled.
Scale will affect the performance of the cooling tower. Cooling tower coils need to be descaled.

8) Maintenance of Water Pump

In order to maintain the original performance of the rolling bearings of the water pump motor and ensure long-term use in good condition, it is necessary to inspect and maintain the bearings according to the specified time to prevent faults, ensure reliable operation, and improve efficiency and efficiency.

For the three-phase asynchronous motor supporting the water pump of water-cooled container products, the maintenance of the motor bearings can be carried out according to this instruction.

The bearing models of the motor supporting the circulating pump product in the current system are shown in the table below:

Table 9-5 Bearing model

Model	Bearing	Quantity	Lubrication oil addition cycle		Grease model
			Poles 2P	Poles 4P	
160	DE:7309B	17	2000h	5400h	Polyrex EM
	NDE:6309ZC3				

Danger

This system uses a 2P main pump, so the refueling cycle is 2000h. Bearing grease must be added after about 83 days of continuous operation, or it must be added regularly as needed.

The method for adding lubricating grease to bearings of SHIMGE water pumps can be found in the following video link:

Website: http://100gs.shimge.com/wap/blbxgdjlxwh_8/2.html;

Caution

When different brands of grease are mixed, their consistency will change greatly. It is prohibited to mix different brands of lubricating grease. If other brands of grease are used, the motor bearings must be removed and the original grease must be cleaned, otherwise there is a risk of burning the motor bearings.

10 ANTSPACE HK3 V6 Container Water Cooling System Safety Instructions

Danger

If the container liquid cooling system is not used for a long time, the main power supply should be turned off. After a long power outage, normal power-on procedures should be followed.

10.1 Maintenance

Only qualified and authorized personnel are allowed to carry out maintenance and other operations on the electrical system.

10.2 Operation

- a) Before starting the cooling system inside the container, a fire extinguisher should be equipped.

Caution

Due to transportation and regulatory limitations, the system is not equipped with a fire extinguisher during shipment. Before operating the system, please provide a fire extinguisher that complies with local regulations of the project. The fire extinguisher bracket must be fixed on the left side of the equipment entrance label on site.

- b) The equipment must have at least two reliable grounding positions, and the protective grounding resistance should be verified to ensure continuity. Its value should be less than 0.3Ω , otherwise there may be a dangerous situation that may cause personal injury or death.
- c) Only clean the equipment after shutting down and turning off the power, otherwise it may cause electric shock or injury. Do not use water to clean the equipment, otherwise it may cause electric shock.
- d) Before starting the machine, be sure to check if the valve (if present) is open.
- e) Safety clauses for operation of distribution cabinets and main control cabinets:

Before operating the distribution cabinet A/B and main control cabinet, it is necessary to ensure that the cabinet door is locked to prevent personal injury such as electric shock, and to prevent salt mist, moisture, dust or other conductive substances from entering the interior of the distribution cabinet and main control cabinet;

When powering on, it is prohibited to touch the single board, cables, terminals, modules, sensors and other equipment inside the cabinet to avoid safety accidents;

If there is a malfunction, odor, or abnormal sound, please close the main circuit breakers MCB-A1, MCB-A2, and QFWCU of the three cabinets, or press the emergency stop button on the container door and two cabinets, otherwise it may cause electric shock or fire accidents;

When the container system is at risk of rapid freezing under abnormal operating conditions, an air pump must be used to remove the cooling water in the system as soon as possible. For air pumps, refer to the recommended model in Chapter 7.2.1).

10.3 Attention

1. Nonprofessional authorized personnel are prohibited from opening the door of the distribution cabinet
2. Only when the main circuit breaker is in the OFF position can the distribution cabinet door be opened.

Danger

The main circuit breaker is in the OFF position, and the front end of the main circuit breaker is live. Unauthorized and professional personnel are prohibited from opening the protective board.

Before using this equipment, please read this manual carefully. If you have any difficulties or problems, please consult authorized personnel from the factory for assistance.